

EPSON TERMINAL PRINTER
EPL-5500

SERVICE MANUAL

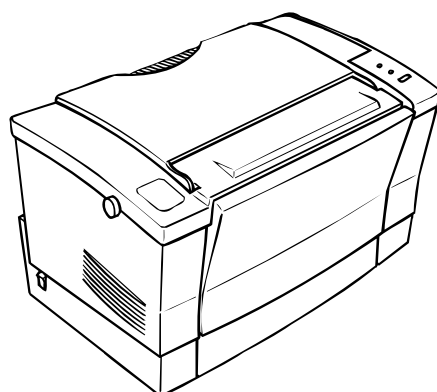

EPSON

4005431

NOTICE

All rights reserved. Reproduction of any part of this manual in any form whatsoever without SEIKO EPSON's express written permission is forbidden.

The contents of this manual are subjects to change without notice.

All efforts have been made to ensure the accuracy of the contents of this manual. However, should any errors be detected, SEIKO EPSON would greatly appreciate being informed of them.

The above notwithstanding SEIKO EPSON can assume no responsibility for any errors in this manual or the consequence thereof.

Epson is a registered trademark of Seiko Epson Corporation.

General Notice: Other product names used herein are for identification purposes only and may be trademarks of their respective companies.

Copyright © 1995 by SEIKO EPSON CORPORATION Nagano, Japan

PRECAUTIONS

Precautionary notations throughout the text are categorized relative to 1) personal injury and 2) damage to equipment.

DANGER Signals a precaution which, if ignored, could result in serious or fatal personal injury. Great caution should be exercised in performing procedures preceded by DANGER Headings.

WARNING Signals a precaution which, if ignored, could result in damage to equipment.

The precautionary measures itemized below should always be observed when performing repair/maintenance procedures.

DANGER

1. ALWAYS DISCONNECT THE PRODUCT FROM BOTH THE POWER SOURCE AND PERIPHERAL DEVICES PERFORMING ANY MAINTENANCE OR REPAIR PROCEDURE.
2. NO WORK SHOULD BE PERFORMED ON THE UNIT BY PERSONS UNFAMILIAR WITH BASIC SAFETY MEASURES AS DICTATED FOR ALL ELECTRONICS TECHNICIANS IN THEIR LINE OF WORK.
3. WHEN PERFORMING TESTING AS DICTATED WITHIN THIS MANUAL, DO NOT CONNECT THE UNIT TO A POWER SOURCE UNTIL INSTRUCTED TO DO SO. WHEN THE POWER SUPPLY CABLE MUST BE CONNECTED, USE EXTREME CAUTION IN WORKING ON POWER SUPPLY AND OTHER ELECTRONIC COMPONENTS.

WARNING

1. REPAIRS ON EPSON PRODUCT SHOULD BE PERFORMED ONLY BY AN EPSON CERTIFIED REPAIR TECHNICIAN.
2. MAKE CERTAIN THAT THE SOURCE VOLTAGE IS THE SAME AS THE RATED VOLTAGE, LISTED ON THE SERIAL NUMBER/RATING PLATE. IF THE EPSON PRODUCT HAS A PRIMARY AC RATING DIFFERENT FROM AVAILABLE POWER SOURCE, DO NOT CONNECT IT TO THE POWER SOURCE.
3. ALWAYS VERIFY THAT THE EPSON PRODUCT HAS BEEN DISCONNECTED FROM THE POWER SOURCE BEFORE REMOVING OR REPLACING PRINTED CIRCUIT BOARDS AND/OR INDIVIDUAL CHIPS.
4. IN ORDER TO PROTECT SENSITIVE MICROPROCESSORS AND CIRCUITRY, USE STATIC DISCHARGE EQUIPMENT, SUCH AS ANTI-STATIC WRIST STRAPS, WHEN ACCESSING INTERNAL COMPONENTS.
5. REPLACE MALFUNCTIONING COMPONENTS ONLY WITH THOSE COMPONENTS BY THE MANUFACTURE; INTRODUCTION OF SECOND-SOURCE ICs OR OTHER NONAPPROVED COMPONENTS MAY DAMAGE THE PRODUCT AND VOID ANY APPLICABLE EPSON WARRANTY.

SAFETY INFORMATION

This printer is a page printer which operates by means of a laser. There is no possibility of danger from the laser, provided the printer is operated according to the instructions in this manual provided.

Since radiation emitted by the laser is completely confined within protective housings, the laser beam cannot escape from the machine during any phase of user operation.

For United States Users;

[Laser Safety]

This printer is certified as a Class 1 Laser product under the U.S. Department of Health and Human Services (DHHS) Radiation Performance Standard according to the Radiation Control for Health and Safety Act of 1968. This means that the printer does not produce hazardous laser radiation.

[CDRH Regulations]

The Center for Devices and Radiological Health (CDRH) of the U.S. Food and Drug Administration implemented regulations for laser products on August 2, 1976. Compliance is mandatory for products marketed in the United States. The label shown below indicates compliance with the CDRH regulations and must be attached to laser products marketed in the United States.

WARNING : Use of controls, adjustments or performance of procedures other than those specified in this manual may result in hazardous radiation exposure.

[Internal Laser Radiation]

Maximum Radiation Power: 5.0×10^{-4} (W)
Wave Length: 790 ± 20 nm

This is a Class IIIb Laser Diode Assay that has an invisible laser beam. The print head unit is NOT A FIELD SERVICE ITEM. Therefore, the print head unit should not be opened under any circumstances.

For Other Countries Users;

WARNING: Use of controls, adjustments or performance of procedures other than those specified in this manual may result in hazardous radiation exposure.

This is a semiconductor laser. The maximum power of the laser diode is 5.0×10^{-4} W and the wavelength is 790 ± 20 nm.

For Denmark Users;

ADVARSEL
Usynlig laserstråling ved åbning, når sikkerhedsafbrydere er ude af funktion.
Undgå udsættelse for stråling.

Klasse 1 laser produkt der opfylder IEC825 sikkerheds kravene.

For Finland, Sweden Users;

VAROITUS

Laitteen käyttäminen muulla kuin tässä käyttöohjeessa mainitulla tavalla saattaa altistaa käyttäjän turvallisuusluokan 1 ylittävälle näkymättömälle laser-säteilylle.

VARNING

Om apparaten används på annat sätt än i denna bruksanvisning specificerats, kan användaren utsättas för osynlig laserstrålning, som överskrider gränsen för laser klass 1.

For Finland, Sweden Service People

VAROITUS

Avattaessa ja suojalukitus ohitettaessa olet alttiina näkymättömälle laser-säteilylle. Älä katso säteeseen.

VARNING

Osynlig laserstrålning när denna del är öppnad och spärren är urkopplad. Betrakta ej strålen.

For Norway Users;

ADVARSEL

Dersom apparatet brukes på annen måte enn spesifisert i denne bruksanvisning, kan brukeren utsettes for usynlig laserstråling som overskrider grensen for laser klasse 1.

Dette er en halvleder laser. Maksimal effekt til laserdiode er 5.0×10^{-4} W og bølgelengde er 790 ± 20 nm.

Laser Safety Labels

[Label on rear printer case]

A laser safety labels is attached on the outside of the printer shown below.

For United State

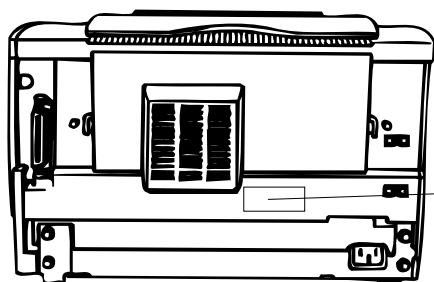

This laser product conforms to the applicable requirement of 21 CFR Chapter I, subchapter J.

SEIKO EPSON CORP.
Hirooka Office
80 Hirooka, Shiojiri-shi, Nagano-ken,
Japan

MANUFACTURED:

For Europe

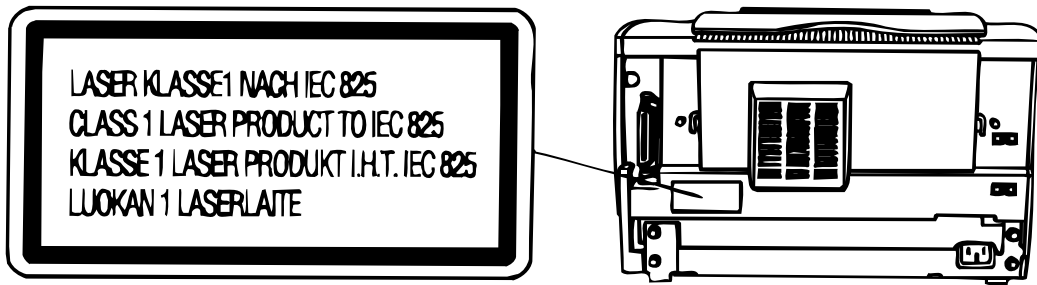

[Label inside printer]

The following laser safety label will be attached inside the printer as shown below.

For Denmark, Finland, Sweden, and Norway

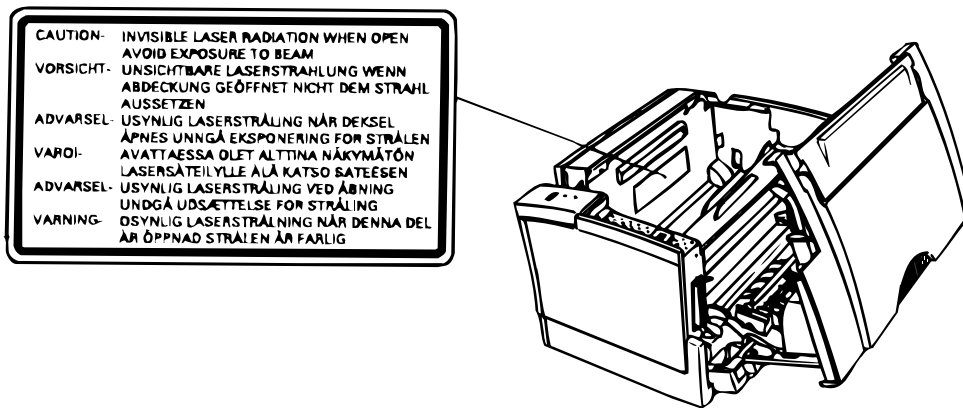

PREFACE

This manual describes functions, theory of electrical and mechanical operations, maintenance, and repair of EPL-5500.

The instructions and procedures included herein are intended for the experience repair technician, and attention should be given to the precautions on the preceding page. The chapters are organized as follows:

CHAPTER 1. GENERAL DESCRIPTION

Provides a general product overview, lists specifications, and illustrates the main components of the printer.

CHAPTER 2. OPERATING PRINCIPLES

Describes the theory of printer operation.

CHAPTER 3. DISASSEMBLY AND ASSEMBLY

Includes a step-by-step guide for product disassembly and assembly.

CHAPTER 4. ADJUSTMENTS

Includes a step-by-step guide for adjustment.

CHAPTER 5. TROUBLESHOOTING

Provides Epson-approved techniques for adjustment.

CHAPTER 6. MAINTENANCE

Describes preventive maintenance techniques and lists lubricants and adhesives required to service the equipment.

APPENDIX

Describes connector pin assignments, circuit diagrams, circuit board component layout and exploded diagram.

The contents of this manual are subject to change without notice.

REVISION SHEET

Revision	Issue Date	Revision Page
Rev. A	October 06, 1995	1st issue
Rev. B	March 15, 1996	Revise the whole pages of the following chapters: Chapter 1 Chapter 2 Chapter 3 Chapter 4 Chapter 5 Chapter 6

Chapter 1 General Description

Table of Contents

1.1 FEATURES	1-1
<hr/>	
1.2 SPECIFICATIONS	1-3
1.2.1 Basic Specification	1-3
1.2.2 Electrical Specifications	1-5
1.2.3 Reliability Specifications	1-5
1.2.4 Environmental Conditions for Operating (Include Imaging Cartridge)	1-5
1.2.5 Environmental Conditions for Storage and Transportation	1-5
1.2.6 Applicable Standards	1-6
1.2.7 Specifications for Consumable	1-6
1.2.8 Physical Specifications	1-6
1.2.9 Software Specifications	1-7
<hr/>	
1.3 INTERFACE SPECIFICATIONS	1-9
1.3.1 Parallel Interface	1-9
1.3.1.1 Compatibility Mode of Parallel Interface	1-9
1.3.1.2 Reverse Mode Mode Signal Timing	1-11
1.3.2 Serial Interface	1-15
1.3.3 Optional LocalTalk Interface	1-17
<hr/>	
1.4 OPERATING INSTRUCTIONS	1-18
1.4.1 Control Panel	1-18
1.4.2 Printer Settings Functions	1-20
1.4.3 Service Mode	1-23
1.4.3.1 Hexadecimal Dump Mode	1-23
1.4.3.2 EEPROM Initialize Mode	1-23
1.4.3.3 Factory Reset Mode	1-23
1.4.3.4 Default Setting Mode	1-24
1.4.4 Display of Messages	1-27
1.4.4.1 Status Messages	1-27
1.4.4.2 Error Messages	1-27
1.4.4.3 Service Call Error Message	1-27
1.4.5 Printer Sharing	1-28
1.4.5.1 Port Fixed Mode	1-28
1.4.5.2 Auto Sense Mode	1-28
1.4.6 Emulation Mode Switch Function	1-29
1.4.6.1 Emulation Switch by SPL	1-29
1.4.6.2 Intelligent Emulation Switch	1-29
1.4.7 Bi Resolution Improvement Technology	1-30
1.4.8 Toner Save Mode	1-31
1.4.9 Optional Memory	1-31
<hr/>	
1.5 MAIN COMPONENTS	1-32
1.5.1 C169 MAIN-B Board	1-33
1.5.2 PWB-E Board	1-34
1.5.3 PWB-F Board	1-34
1.5.4 Optical Unit	1-35
1.5.5 FUSING UNIT	1-35
1.5.6 Photoconductor Unit	1-36

1.5.7 Developing Cartridge	1-36
1.5.8 Lower Paper Cassette Unit	1-36

List of Figures

Figure 1-1. Exterior View of the EPL-5500	1-1
Figure 1-2. Printable Area	1-4
Figure 1-3. Compatibility Mode Signal Timing	1-9
Figure 1-4. Parallel Interface State Switch Diagram	1-12
Figure 1-5. Negotiation Timing Chart	1-13
Figure 1-6. Timing Chart of Data Transfer	1-13
Figure 1-7. Termination Timing Chart	1-14
Figure 1-8. Timing Chart of Interrupt	1-14
Figure 1-9. Control Panel	1-18
Figure 1-10. Port Fixed Mode	1-28
Figure 1-11. Auto Sense Mode	1-28
Figure 1-12. Emulation Switch by SPL	1-29
Figure 1-13. Intelligent Emulation Switch	1-29
Figure 1-14. Effect of RITech	1-30
Figure 1-15. RITech Adjustment	1-30
Figure 1-16. Toner Save Mode	1-31
Figure 1-17. Component Layout	1-32
Figure 1-18. C169 MAIN-B Board	1-33
Figure 1-19. PWB-E Board	1-34
Figure 1-20. PWB-F Board	1-34
Figure 1-21. Optical Unit	1-35
Figure 1-22. Fusing Unit	1-35
Figure 1-23. Photoconductor Unit	1-36
Figure 1-24. Developing Cartridge	1-36

List of Tables

Table 1-1. Options for the EPL-5500	1-2
Table 1-2. Paper Feed Methods	1-3
Table 1-3. Paper Types	1-3
Table 1-4. Usability of Special Papers	1-4
Table 1-5. Electrical Specifications	1-5
Table 1-6. Differences between EPSON GL/2 and GL/2 in the HP LaserJet® 4 Emulation	1-7
Table 1-7. Built-in Fonts	1-7
Table 1-8. Parallel Interface Pin Assignment	1-10
Table 1-9. Parallel Interface Pin Assignment	1-11
Table 1-10. Serial Interface Connector Pin Assignments	1-15
Table 1-11. LocalTalk Connector Pin Assignments	1-17
Table 1-12. Printer Settings	1-20
Table 1-13. Service MOde Select Timing	1-23
Table 1-14. Default Settings Codes	1-24
Table 1-15. Error Messages	1-27
Table 1-16. Differences in Components for the C169 MAIN-B Board	1-33

1.1 FEATURES

The EPSON® EPL-5500 is non-impact page printer that combines a semi-conductor laser with electrophotographic technology. This printer is small and light, and features high-speed, high-resolution printing. Maintenance is very easy as a result of various built-in diagnostic functions. The main features are:

- No ozone
- Printing speed — 6 ppm (pages per minute)
- Resolution — 600/300 dpi (dots per inch)
- Light weight — about 5 kg (11 lb)
- Small footprint
- Low running cost: separation of the development/toner cartridge and photoconductor unit
- HP® LaserJet® 4 emulation mode
- 22 built-in scalable fonts (8 Agfa® and 14 TrueType® fonts)
- High-performance controller (the controller's CPU is a 22.5 MHz SPARKlite (MB86933H))
- Bi Resolution Improvement Technology (BiRITech) refines the print quality by eliminating jagged edges from images and characters on 600 dpi and 300 dpi printing
- Memory Improvement Technology supported
- Optional EPSONScript Level 2 (PostScript® compatible) module
- Optional WPS (Windows Printing System) ROM SIMM module
- Optional I239X, ESC/P 2™, and FX emulation ROM SIMM module
- EPSON Micro Gray Technology (EMGTech), which is available when using PCL and EPSONScript Level 2 mode, refines gray scale printing to be comparable to printing on a 1200-dpi printer
- Small and low-cost optional LocalTalk™ with serial interface module
- 1MB standard RAM and memory expansion available up to 32MB of RAM with the addition of optional SIMMs
- Bidirectional parallel interface
- Toner-saver mode supported
- A multi-user, multi-emulation mode
- IES (Intelligent Emulation Switch) allows switching between EPSONScript mode and another mode
- SPL (Shared Printer Language) enables switching of the printer mode by command

Figure 1-1 shows an exterior view of the EPL-5500.

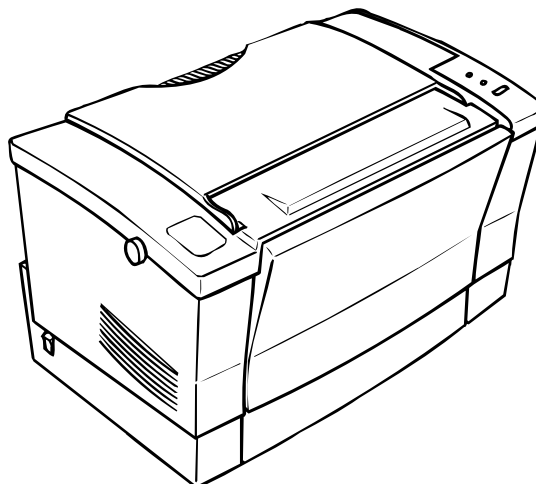

Figure 1-1. Exterior View of the EPL-5500

Table 1-1 lists the optional units available for the EPL-5500.

Table 1-1. Options for the EPL-5500

Cat. No.	Description	Note
C83218*	Windows Printing System ROM SIMM	Supports Windows Printing System
C83219*	EPSONScript Level 2 ROM SIMM	Supports EPSONScript Level 2 mode (PostScript Level 2 compatible) fonts and commands (see Note 1)
C83220*	LQ/FX/I239X ROM SIMM	Supports ESC/P 2, FX, and IBM 2390/2391 emulation modes
—	NLSP Bitmap 2 font ROM	Supports local NLSP bitmap fonts (see Note 2)
—	NLSP Scalable font ROM	Supports local NLSP scalable fonts (see Note 2)
C812491	250-sheet lower paper cassette for the EPL-5500 (A4/B5)	Lower paper cassette
S050005	Developer cartridge	Developer and toner cartridge
S051029	Photoconductor unit	—
C82334*	LocalTalk™ with serial I/F module	(see Note 3)
C83614*	Interface cable	RS-232C extension cable for C82334*
C82335*	Type-B EX box	Type-B I/F card box (see Note 4)
C82307*/ C82308*	32 KB serial interface card	(see Note 5)
C82310*/ C82311*	32 KB parallel interface card	(see Note 5)
C82312*	LocalTalk card	(see Note 5)
C82313*	GPIB card	(see Note 5)
C82314*	COAX interface card	(see Note 5)
C82315*	TWINAX interface card	(see Note 5)
C82324*	Ethernet interface card for NetWare®	(see Note 5)
C82328*	FAX card	(see Note 5)
C82331*	Multi protocol Ethernet card	(see Note 5)

Notes:

1. Requires added memory (RAM) over a total of 2 MB, including standard RAM.
2. NLSP font ROMs do not support ESC/P 2 and FX modes.
3. LocalTalk with serial I/F module (C82334*) cannot be used with Type-B EX box (C82335*).
4. Type-B EX box (C82335*) cannot be used with LocalTalk with serial I/F module (C82334*) .
5. Type-B EX box (C82335*) must be installed while using the Type-B I/F card.

1.2 SPECIFICATIONS

This section provides statistical data for the EPL-5500.

1.2.1 Basic Specifications

Printing method:	Laser beam scanning and dry electrophotography
Resolution:	600/300 dpi
Printing speed:	6 ppm (letter/A4)
First printing time (A4/LT):	Less than 20 seconds (face-up output)
Warm-up time:	Less than 35 seconds (at rated current and 23° C (73° F) temperature)
Paper supply:	See Table 1-2.

Table 1-2. Paper Feed Methods

Paper Supply	Capacity Using 20 lb. (75 g/m ²) Paper	Paper Size	Usage Thickness (Ream Weight)
Standard built-in paper tray	150	A5, B5, A4, LT, GLT, EXE, LGL, GLG, F4, HL	16 to 24 lb. (60 to 90 g/m ²)
	5 to 10	Monarch, DL, C5, C6, International B5, Commercial-10	Envelopes made of 20 to 24 lb. (75 to 90 g/m ²) paper
Manual feed slot	1	Any size feedable (Note 2)	16 to 42 lb. (60 to 157 g/m ²)
Lower paper cassette (optional)	250	A4, B5	16 to 24 lb. (60 to 90 g/m ²)

Notes:

- The weight in pounds (lb) is determined by the weight of 500 sheets cut to 17 × 22 inches;
1 g/m² = 0.2659763 lb.
- Paper size range: width 3 to 8.5 inches (76 to 216 mm)
length 5 to 14.0 inches (127 to 356 mm)

Paper types: See Table 1-3.

Table 1-3. Paper Types

Standard paper	Xerox® 4024 DP paper 20 lb (75 g/m ²)
Normal paper	Regular photocopier paper Bond paper Recycled paper 16 to 24 lb (60 to 90 g/m ²)
Special papers	Card stock (90 to 157 g/m ²) Envelopes Labels Letterhead Transparency (OHP) sheets Colored paper

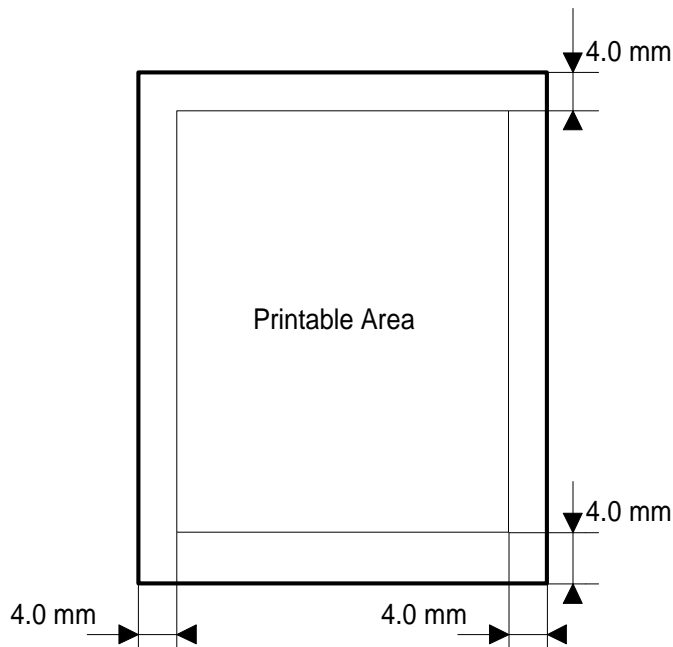

Figure 1-2. Printable Area

Usability of special papers: See Table 1-4.

Table 1-4. Usability of Special Papers

Input	OHP	Envelopes	Labels	Card Stock	Letterhead
Standard built-in paper tray	P	P	P	P	R
Manual feed slot	P	P	P	P	R
Lower paper cassette	N	N	N	N	P

R: Reliable feeding and good image quality.

P: Possible, but better avoided.

N: Not supported.

Paper feed alignment and direction: Center alignment for all sizes

Paper ejection: Face down

Output tray capacity: 100 sheets (face down)

Printable area (standard paper): See Figure 1-2.

Note: The actual printable area depends on the printer mode.

Noise: Less than 35 dB(A), standby
Less than 47 dB(A), operating

Ozone density: Less than 0.01 ppm

Toxicity: No toxicity exists in organic photoconductor (OPC), toner, or plastic materials

1.2.2 Electrical Specifications

Table 1-5. Electrical Requirements and Ranges

Description	100 V Version	200 V Version
Rated voltage	100 ~ 120 VAC	220 ~ 240 VAC
Input voltage range	90 ~ 132 VAC	198 ~ 264 VAC
Rated frequency range	50 ~ 60 Hz	
Input frequency range	47 ~ 63 Hz	
Power consumption	Less than 500 W	Less than 600 W
Power consumption while in standby mode	Less than 15 W (without option)	

1.2.3 Reliability Specifications

MPBF (Mean Prints Between Failures): Over 25,000 sheets

Note: MPBF indicates average number of pages printed before occurrence of problem requiring replacement or service.

MTBF (Mean Time Between Failures): 3000 power on hours (POH)
 Jam rate: 1 out of 2,000 sheets or less (excluding multiple-sheet feeding)
 Feed failure: 1 out of 2,000 sheets or less (excluding multiple-sheet feeding)
 Multiple paper feeds: 1 out of 500 sheets or less
 Paper curl height: 30 mm (1.2 inches) or less
 Leading edge bending (1 cm or more): 1 out of 1,000 sheets
 MTTR (Mean Time To Repair): 30 minutes or less
 Durability: 5 years or 180,000 sheets

1.2.4 Environmental Conditions for Operation (Including Imaging Cartridge)

Temperature: 10 to 35° C (50 to 95° F)
 Humidity: 15 to 85% RH
 Altitude: 2,500 m (8,200 feet) or lower
 Levelness: 1°
 Illuminance: 3,000 lux or less (Must not be exposed to direct sunlight.)
 Surrounding space: Printer should have at least 100 mm of clearance on its sides and rear.

1.2.5 Environmental Conditions for Storage and Transportation

Temperature: 0 to 35° C (32 to 95° F)
 Humidity: 30 to 85% RH
 Drop test: Clear to JIS Z0200-1987 Level 1
 Vibration: Vibration frequency 5 to 100 Hz and 100 to 5 Hz
 Acceleration 1 G
 Acceleration direction 3 direction
 Resistance to atmospheric pressure: More than 61.3 KPa
 Storage life: 18 months (following date of manufacture)

1.2.6 Applicable Standards

Safety Standards

120 VAC model:	UL 1950, CSA 22.2 No. 950 Deviation 3
220/240 VAC model:	EN 60950 (IEC950), NEMKO (IEC950), SETI (IEC950), SEMKO (IEC950), DEMKO (IEC950)

Safety Regulations (Laser Radiation)

120 VAC model:	FDA (NCDRH) Class 1
220/240 VAC model:	VDE 0837 (Laser Class 1) (IEC825), SETI (IEC825), SEMKO (IEC825), DEMKO (IEC825)

EMI

120 VAC model:	FCC Part 15 Subpart B Class B, DOC Class B
220/240 VAC model:	Vfg 243 (VDE 0878 Part 3,30) EN55022 Class B (CISPR Pub.22 Class B) CE marking, EMC

Others

Toner:	No effect on human health (OSHA-TSCA, EINECS)
OPC:	No effect on human health (OSHA)
Ozone:	Less than 0.01 mmp other UL478 (5th edition)
Materials:	SWISS environmental law (must contain no CdS)

1.2.7 Specifications for Consumables

Life:	Developer and toner cartridge: 3,000 pages Photoconductor unit: 20,000 pages
-------	---

Note: In continuous printing mode with A4/letter paper at a 5% image ratio (black/white ratio). The life varies, depending on the printing mode (continuous or intermittent) and/or the image ratio.

Environmental Conditions for Storage and Transportation

Temperature:	0 to 35° C (32 to 95° F)
Humidity:	30 to 85% RH
Drop test:	Height 76 cm (30.4 inches)
Vibration:	Same as printer
Resistance to atmospheric pressure:	More than 74 Kpa
Storage term:	18 months (following date of manufacture)

1.2.8 Physical Specifications

Dimensions (Width × Depth × Height):

Printer:	352 × 264 × 299 mm (13.9 × 10.4 × 11.8 inches)
Weight:	Approx. 5 kg (11 lb), with consumables, excluding all options

1.2.9 Software Specifications

Built-in modes: HP LaserJet 4 emulation (PCL[®] 5e)
EPSON GL/2 mode (GL-like mode)

Note: EPSON GL/2 mode is similar to the GL/2 mode included in the HP LaserJet 4 emulation. Table 1-6 shows the differences between EPSON GL/2 mode and the LJ4 GL/2 mode. While in EPSON GL/2 mode, the operator can enter GL/2 mode without sending the ESC %B (Enter GL/2 mode) command. If the operator's application software cannot send the ESC %B command, then use this mode.

Table 1-6. Differences between EPSON GL/2 and GL/2 in the HP LaserJet 4 Emulation

	EPSON GL/2 Mode	GL/2 for HP LaserJet 4 Emulation Mode
PCL mode	Not available	Initial mode
Paper eject	Supports PG, AF commands	Supported in PCL
Auto eject	SelecType setting	Not available
Reduced printing	SelecType setting	Available in PCL
Switch to PCL (ESC %A)	Not supported	Supported
Reset (ESC E)	Ejects paper and then initializes	Ejects paper, switches to PCL, and then initializes
PJL, EJL, and ES	Supported	Supported
Advance full page (PG, AF)	Supported	Not supported

Note: The EPL-5500 GL/2 mode features all the commands of the LJ4-GL/2 mode, plus a few additional commands. The GL/2 mode emulates some of the HP-GL[®] plotter (HP 7475A, etc.) commands. If the application software uses unsupported commands for the GL/2 mode, print cannot be assured.

Optional modes: EPSONScript Level 2 (PostScript Level 2 emulation) mode
FX (FX-870/1170, LX-100) emulation mode
ESC/P 2 (Stylus 800/1000) emulation mode
WPS (Windows Printing System) mode

Auxiliary software: Hex dump
Status sheet
Font sample

Built-in fonts: See Table 1-7.

Table 1-7. Built-in Fonts

Resident Fonts	Applicable Mode
	HP LJ4, GL/2
Bitmap fonts	
Line Printer16.66 cpi(Portrait)	S
Scalable fonts	
Dutch [™] 801Roman SWC	S
Dutch 801Bold SWC	S
Dutch 801Italic SWC	S
Dutch 801Bold Italic SWC	S
Swiss [™] 742SWC	S
Swiss 742Bold SWC	S
Swiss 742Medium Italic SWC	S

S: Supported, NS: Not Supported

Table 1-7. Built-in Fonts (Continued)

Resident Fonts	Applicable Mode
	HP LJ4 GL/2
Scalable fonts	
Swiss 742Bold Italic SWC	S
Swiss 721Roman SWM	S
Swiss 721Bold SWM	S
Swiss 721Oblique SWM	S
Swiss 721Bold Oblique SWM	S
Dutch 801Roman SWM	S
Dutch 801Bold SWM	S
Dutch 801Italic SWM	S
Dutch 801Bold Italic SWM	S
Symbol SetSWA	S
More WingBatsSWM	S
CourierSWC	S
CourierBold SWC	S
CourierItalic SWC	S
CourierBold Italic SWC	S

S: Supported, NS: Not Supported

1.3 INTERFACE SPECIFICATIONS

The EPL-5500 is equipped with the following external interfaces:

- Parallel interface
- Optional LocalTalk/serial interface
- Optional Type B interface with Type-B EX box

1.3.1 Parallel Interface

The parallel interface has the following two modes:

- Compatibility mode (same as parallel interface for EPSON's current page printer)
- Reverse mode

1.3.1.1 Parallel Interface Compatibility Mode

System:	STROBE synchronization, 8-bit parallel data transfer
Handshaking:	BUSY and $\overline{\text{ACKNLG}}$ signals
Connector type:	P90-25027-1 (Amphenol) receptacle
Applicable plug:	57-30360 (Amphenol or equivalent)
Transfer speed:	Approximately 400,000 bytes/second (max.)
Signal timing:	See Figure 1-3.
Signal description:	See Table 1-8.

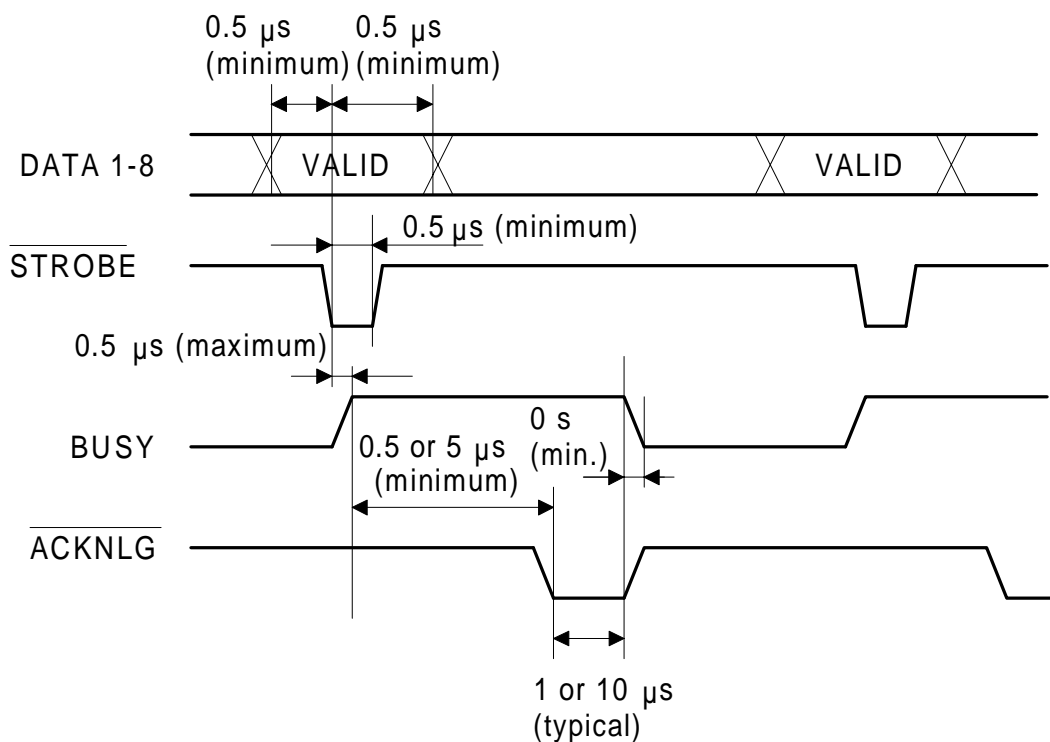

Figure 1-3. Compatibility Mode Signal Timing

Table 1-8. Parallel Interface Pin Assignments

Pin No.	Signal Name	I/O	Description
1	$\overline{\text{STROBE}}$	IN	$\overline{\text{STROBE}}$ is a strobe pulse used to read data from the host computer. The pulse width must be more than 0.5 μsec . Normally it is HIGH, and data is latched at the trailing edge of this signal.
2-9	DATA 1-8	IN	DATA 1 to 8 are parallel data bits. When the signal is HIGH, the data bit is 1, and when it is LOW, the data bit is 0. The most significant bit (MSB) is DATA 8. The signal state must be maintained for 0.5 μsec . on either side of the $\overline{\text{STROBE}}$ signal active edge.
10	$\overline{\text{ACKNLG}}$	OUT	$\overline{\text{ACKNLG}}$ is an acknowledge pulse with an approximate width of 1 or 10 μsec . This signal goes LOW when the data reception is completed, which indicates that the printer can accept new data. Timing with the BUSY signal is specified through SelecType.
11	BUSY	OUT	The BUSY signal informs the host computer of the printer state. When the signal is HIGH, the printer cannot accept data.
12	PE	OUT	The PE signal indicates paper empty for the standard tray selected through SelecType or command, or for the optional paper cassette. Paper empty is indicated by HIGH.
13	SLCT	OUT	Used in reverse mode.
14	$\overline{\text{AUTO-FEED}}$	IN	Not used.
15	NC	—	Not used.
16	GND	—	Logic ground level.
17	CHASSIS GND	—	Connected to the printer chassis. The printer chassis GND and the signal GND are connected to each other.
18	NC	—	Not connected.
19-30	GND	—	Ground level for the twisted pair return signal.
31	$\overline{\text{INIT}}$	IN	The $\overline{\text{STROBE}}$ signal is ignored when this signal is LOW.
32	$\overline{\text{ERROR}}$	OUT	This level goes LOW when the printer is: <ul style="list-style-type: none"> • Out of paper • Paper jam • In the error state • Off line
33	GND	—	Same as for pins 19 to 30.
34	NC	—	Not used.
35	+5	—	Pulled up to +5 V through 1.0K-ohm resistance.
36	$\overline{\text{SLCT IN}}$	—	Used in reverse mode.

1.3.1.2 Reverse Mode

Reverse mode for the EPL-5500 supports the IEEE-P1284 nibble mode. This printer can run in reverse mode, in which the printer can inform the computer of its status with EIJ and PJJ commands.

System: IEEE-P1284 nibble mode
 Connector type: P90-25027-1 (Amphenol) receptacle
 Applicable plug: 57-30360 (Amphenol or equivalent)
 Signal description: See Table 1-9.

Table 1-9. Parallel Interface Pin Assignment

Pin No.	Signal Name	I/O	Description
1	$\overline{\text{STROBE}}$	IN	HostClk: This signal is a strobe pulse used to read extension request values from the host computer during negotiation.
2-9	DATA 1-8	IN	These signals are data bits of extension request values received during negotiation. This printer supports following values: 0000 0100: Request Device ID (sent in nibble mode) 0000 0000: Request nibble mode
10	$\overline{\text{ACKNLG}}$	OUT	PtrClk: Printer sends clock data.
11	BUSY	OUT	PtrBusy: Printer sends data bits 3 and 7 during data transfer to host computer.
12	PE	OUT	AckDataReq: Printer sends data bits 2 and 6 during data transfer to host computer.
13	SLCT	OUT	Xflag: Printer sends data bits 2 and 6 during data transfer to host computer.
14	$\overline{\text{AUTO-FEED}}$	IN	HostBusy: This signal informs the printer of the host computer's state. When the signal is HIGH, the host computer cannot accept data.
15	NC	—	Not used.
16	GND	—	Logic ground level.
17	CHASSIS GND	—	Connected to the printer chassis. The printer chassis GND and the signal GND are connected to each other.
18	NC	—	Not connected.
19-30	GND	—	Ground level for the twisted pair return signal.
31	$\overline{\text{INIT}}$	IN	nInit: Fixed at HIGH level.
32	$\overline{\text{ERROR}}$	OUT	nDataAvail: Printer sending data bits 0 and 4 during data transfer to host computer.
33	GND	—	Same as for pins 19 to 30.
34	NC	—	Not used.
35	+5	—	Pulled up to +5 V through 1.0K-ohm resistance.
36	$\overline{\text{SLCT IN}}$	IN	1284Active: If this signal is set to HIGH, this printer is actively in P1284 (reverse mode).

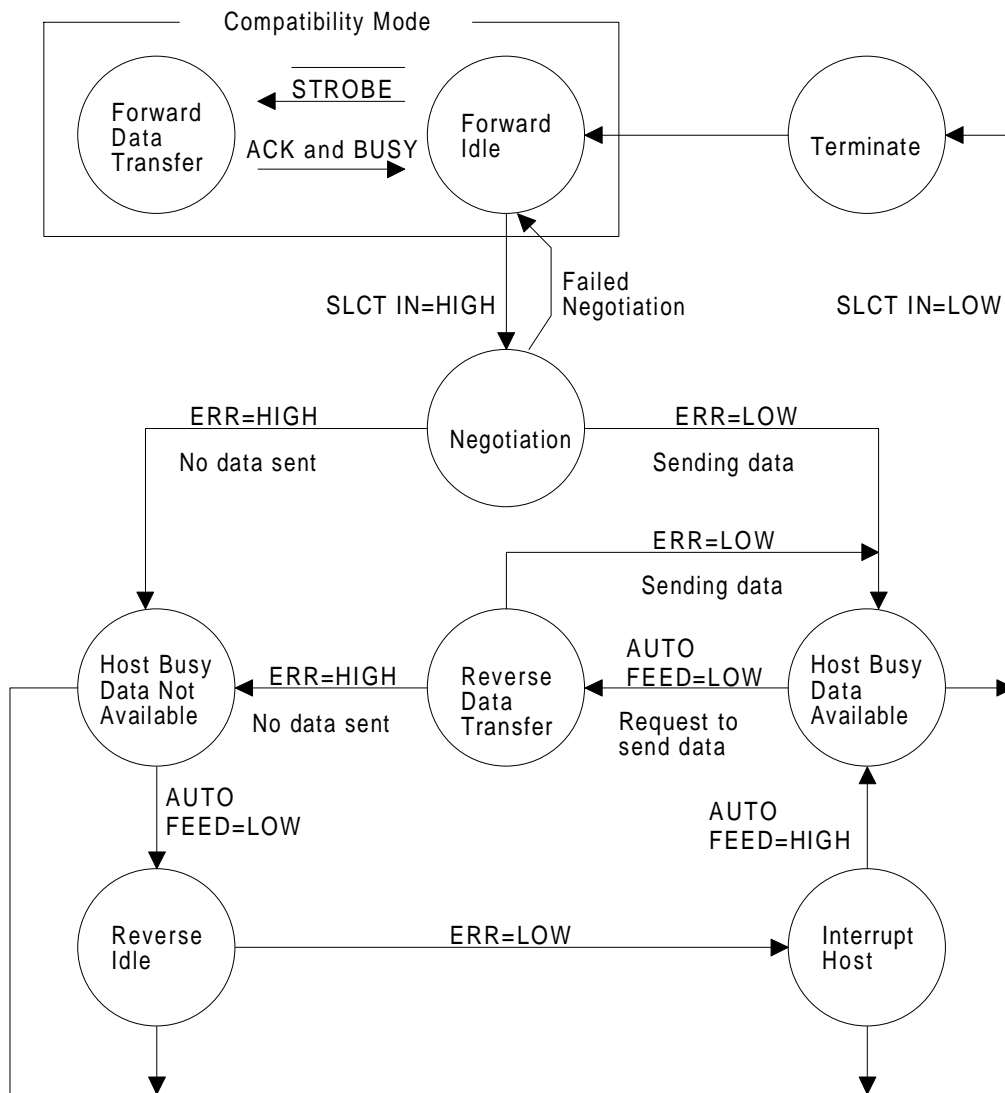

Figure 1-4. Parallel Interface State Switch Diagram

Figure 1-4 shows the switch diagram for the parallel interface state.

Figure 1-5 shows the negotiation timing chart.

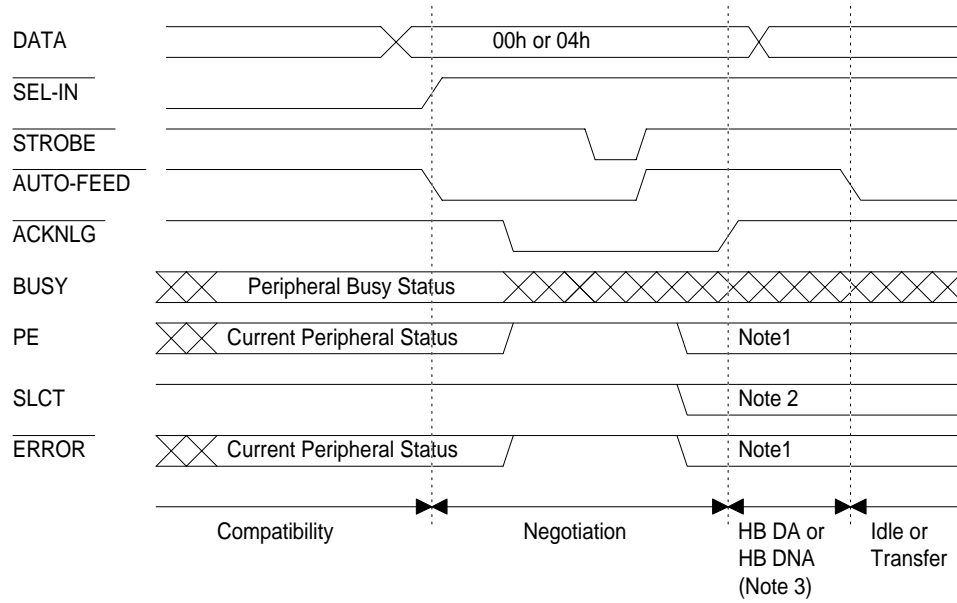

Figure 1-5. Negotiation Timing Chart

Notes:

1. This signal is set to HIGH when no data is being sent. This signal is set to LOW during sending of data.
2. This signal is set to HIGH if the extension request value was 04h.
3. HB DA: Host Busy Data is Available
HB DNA: Host Busy Data is Not Available

Figure 1-6 shows the data transfer timing chart.

Notes:

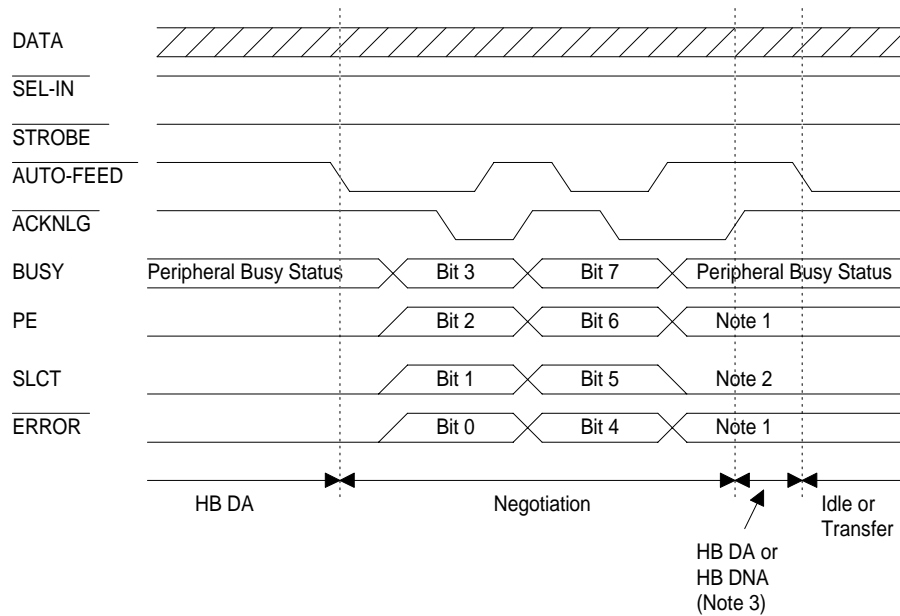

Figure 1-6. Timing Chart for Data Transfer

1. This signal is set to HIGH when no data is being sent. This signal is set to LOW during sending of data.
2. This signal is set to HIGH, if extension request value was 04h.
3. HB DA: Host Busy Data is Available
HB DNA: Host Busy Data is Not Available

Figure 1-7 shows the timing chart for termination.

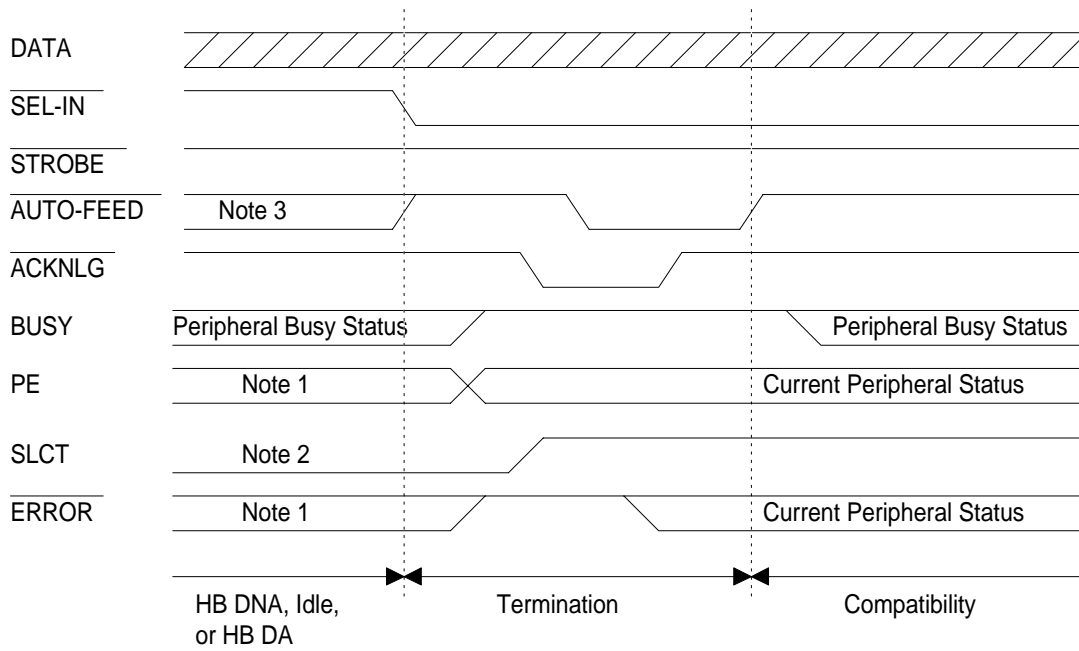

Figure 1-7. Termination Timing Chart

Notes:

1. The signal is HIGH when HB DNA.
The signal is LOW when HB DA.
2. The signal is set to HIGH, if the extension request value was 04h.
3. Idle = LOW.

Figure 1-8 shows the timing chart for interrupts.

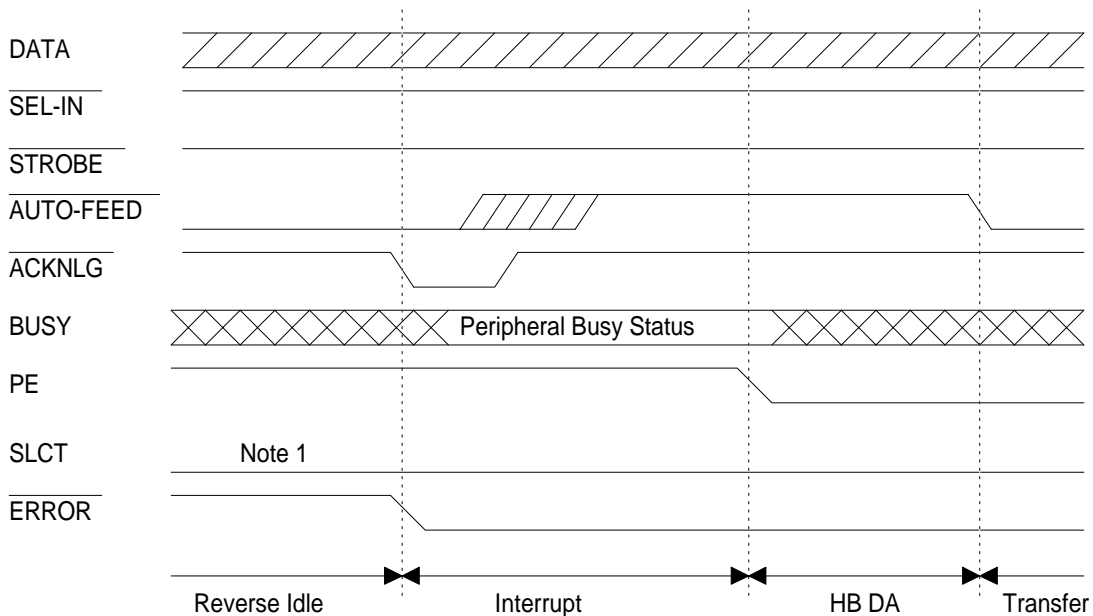

Figure 1-8. Timing Chart for Interrupts

Note: The signal is set to HIGH, if the extension request value was 04h.

1.3.2 Serial Interface

This printer can use the optional LocalTalk/serial interface module.

Type:	RS-232C/current loop		
Transfer system:	Full duplex		
Synchronization:	Asynchronous start-stop system		
	Start-bit:	1 bit	
	Stop-bit:	1 or 2 bits	
	Data length:	7 bits or 8 bits	
	Parity:	Odd, even, or none	
Protocol:	X-ON/X-OFF (can be combined with DTR control)		
	DTR control (can be combined with X-ON/X-OFF)		
Transfer speed:	300, 600, 1200, 2400, 4800, 9600, 19200, 38400, or 57600 bps		
Error:	Overrun error:	Processed as missing data and replaced by “*”	
	Parity error:	Replaced by “*”	
	Framing error:	Replaced by “*”	
	Breaking character:	Ignored	
Signal description:	See Table 1-10.		

Table 1-10. Serial Interface Pin Assignments

Pin No.	Signal Name	I/O	Description
1	CHASSIS-GND	—	Connected to the printer chassis. The printer chassis GND and signal GND are connected to each other.
2	TXD	OUT	Serial ASCII data output by the printer. It maintains the “MARK” state (LOW level) between transmitted character codes. Logic 0 is at HIGH level (SPACE) and logic 1 is at LOW level (MARK).
3	RXD	IN	Serial ASCII data input to the printer. It maintains “MARK” state (LOW level) between received character codes.
5	CTS	IN	Always ignored.
7	SIGNAL-GND	—	Ground.
17	TTY-TXD	OUT	Current loop signal: HIGH impedance (SPACE) between pins 17 and 24 or X-ON signal sent across pins 17 and 24 indicates that the printer is ready to accept data; LOW impedance (MARK) or X-OFF signal being sent indicates that the printer is busy.
20	DTR	OUT	Signal output by printer. When the DTR signal is HIGH, the printer can receive the RXD signal. The SelecType settings do not specify DTR control, the signal level is HIGH while printer power is on. When the SelecType setting is used for DTR control, DTR goes LOW in case of any error conditions. The data (RXD) from host computer must be stopped within 128 characters after DTR goes LOW.
23	TTY-RXD Return	—	Current loop signal: Current return for pin 17
24	TTY-TXD Return	—	Current loop signal: Input data current loop
25	TTY-RXD	IN	Current loop signal: Current return for pin 25

Note : The DTR state can be selected through printer settings.

Handshaking

When the vacant area for data in the input buffer drops to 256 bytes, the printer outputs an X-OFF code or sets the DTR signal level to LOW, indicating that the printer cannot receive more data. Once the vacant area for data in the buffer recovers to 512 bytes, the printer outputs an X-ON code or sets the DTR flag to HIGH, indicating that the printer is again ready to receive data.

Protocol

There are two types of protocols, as listed below, and each of them can be designated by SelectType independently.

□ DTR/DSR protocol

SelectType is used to execute the DTR/DSR control protocol. The DTR signal is set to HIGH when the printer is ready to receive data, and to LOW when conditions indicate an error or that the receiving buffer is full.

When the error is cleared and the printer returns to on-line mode, the signal returns to HIGH. When SelectType is used to set the DTR control OFF, DTR is always set to HIGH. The printer transmits TXD only when DSR is at the HIGH level (DSR is always considered HIGH when the SelectType setting for DSR is OFF). X-ON/X-OFF transmission is independent of the DSR state.

□ X-ON/X-OFF (DC1/DC3) protocol

SelectType is used to execute the X-ON/X-OFF protocol. The X-OFF (DC3) code is output if status indicates an error, and the printer warns the host to stop data transmission within 256 characters. No further X-OFF codes are sent in response to additional data received from the host after the X-OFF code has been sent once. The X-ON (DC1) code is output after all conditions given in the error are cleared.

When the remaining capacity of the receive buffer reaches 512 characters, X-OFF (DC3) is output once. It is sent only once, even if there are multiple errors. The printer goes on line automatically at power on, and outputs an X-ON code. Transmission of X-ON/X-OFF codes can be defined by SelectType.

1.3.3 Optional LocalTalk Interface

This printer can use the optional LocalTalk/ serial interface module.

Type: LocalTalk
 Signal level: Same as RS-422 signal level
 Protocol: X-ON/X-OFF (cannot be combined with DTR control)
 DTR control (cannot be combined with X-ON/X-OFF)
 Transfer speed: 230.4K bps
 Signal description: See Table 1-11.

Table 1-11. LocalTalk Interface Pin Assignments

Pin No.	Signal Name	I/O	Description
1	DTR	OUT	Signal output by the printer. When the DTR signal is HIGH, the printer can receive the RXD signal.
2	CTS	IN	The printer transmits the data through TXD while CTS is HIGH.
3	TXD-	OUT	Serial ASCII data output from the printer. HIGH level; when SD+ voltage is higher than the SD- voltage. LOW level; when SD+ voltage is less than the SD- voltage. Logic 0 is SPACE and logic 1 is MARK. The state must be maintained between transmitted character codes.
4	GND	—	Ground.
5	RXD-	IN	Serial ASCII data input from computer. HIGH level; when RD+ voltage is higher than RD- voltage. LOW level; when RD+ voltage is less than RD- voltage. Logic 0 is "SPACE" and logic 1 is "MARK" state must be maintained between transmitted character codes.
6	TXD+	OUT	Refer to TXD-.
7	NC	—	No connect.
8	RXD+	IN	Refer to RXD-.

1.4 OPERATING INSTRUCTIONS

This section describes functions performed through the control panel, such as printing a status sheet, hexadecimal dump, and printer settings functions.

1.4.1 Control Panel

The printer control panel gives you easy control over most common printer operations. The panel consists of indicator lights and a button.

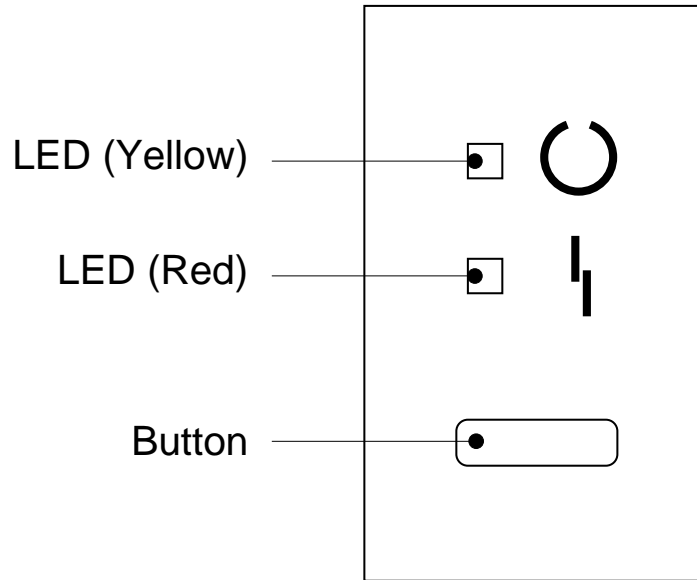

Figure 1-9. Control Panel

Indicator lights

□ Yellow light

ON: Communication with the host is possible.

Fast flashing: Receiving data or warming up.

Slow flashing: Received data is stored in the printer but has not been printed.

OFF: Printer is power off.

□ Red light

ON: Paper jam or cover open.

Fast flashing: Feed jam, paper empty.

Slow flashing: One of these errors: SOFT ERROR, PRINT OVERRUN, MEMORY OVERFLOW, CHECK PAPER SIZE, IMAGE OPTIMUM

OFF: No error condition.

Functions of Pressing the Button

- While the Red light flashes slowly:

Function of button Clears an error.
Operation Hold down the button until the yellow and Red lights both go on after release. The printer prints a status sheet indicating the error type.

- While the Red light flashes fast:

Function of button Prints any of the following page.
 - Feed jam or paper empty page
 - Manual feed page
Operation Load the paper or clear the jam, and then hold down the button until the yellow and Red lights go on, then release to continue printing.

- While yellow light is flashing slowly (except in EPSONScript mode):

Function of button Prints out data in the printer's memory.
Operation Hold down the button until the yellow and red lights go on, then release the button to continue printing.

- While the yellow light is on (except in WPS mode):

Function of button Prints a status sheet.
Operation Hold down the button until the yellow and red lights go on, then release the button to continue printing. The yellow light flash while the status sheet is being printed.

- Reset (always effective except during warm up or status sheet printing):

Function of button Clears current port.
Operation Hold down the button until the yellow and red lights go on, and when these lights start flashing alternately, release the button.

- Warm boot (always effective except during warm up or status sheet printing):

Function of button Warm boot (same as power on reset, except for engine initialization).
Operation Hold down the button until the yellow and red lights start flashing at the same time, then release the button.

1.4.2 Printer Settings Functions

The printer settings function from the Remote Control Panel (software) lets the user control most of the printer's functions, such as printing test pages, selecting a paper size, and changing the printer's configuration. Table 1-12 shows the printer settings options.

Table 1-12. Printer Settings

Menu	Item	Available Options
PRINTING	COPIES	1 to 999
	PAGE SIZE	A4, A5, B5, LT, HLT, LGL, GLT, GLG, EXE, F4, MON, C10, DL, C5, IB5, CTM
	ORIENTATION	PORT, LAND
	MANUAL FEED	OFF, ON
	RITech	OFF, LIGHT, MEDIUM, DARK
	TONER SAVE	OFF, ON
LJ4	FONT SRC	RESIDENT, SIMM, DOWNLOAD
	FONT NUMBER	0 to (available)
	PITCH	0.44 to 99.99 CPI (0.01 steps)
	HEIGHT	4.00 to 999.75 PT. (0.25 steps)
	SYMSET	Roman-8, ECM94-1, 8859-2 ISO, 8859-2 ISO, IBM-US, IBM-DN, PcMultiling, PcE.Europe, PcTk437, WiAnsi, WiE.Europe, WiTurkish, DeskTop, PsText, VeInternati, VeUS, MsPublishin, Math-8, PsMath, VeMath, PiFont, Legal, UK, ANSI ASCII, Swedis2, Italian, Spanish, German, Norweg1, French2, Windows
	FORM	5 to 128 lines
	SRC SYMSET*	0 to 3199
DEST SYMSET*	0 to 3199	
PS*	ERR SHEET	OFF, ON
	MicroGray	OFF, ON
	PROTECT LEVEL	1 to 5
ESCP2*	Font	Courier, Roman, Sans serif, Roman-T, Sans-H, Script
	Pitch	10 CPI, 12 CPI, 15 CPI, Prop
	Condensed	OFF, ON
	T-Margin	0.40 to 1.50 Inch (0.05 steps)
	Text	1 to (available) lines
	CG Table	Pc USA, Italic, PcMultilin, PcPortuguese, PcCanFrenc, PcNordic, PcTurk2, Pc.E.Europe, BpBRASCII, BpAbicom
	Country	USA, France, Germany, UK, Denmak, Sweden, Italy, Spain1, Japan, Norway, Denmark2, Spain2, LatinAmeric, Korea, Legal

* With option

Table 1-12. Printer Settings (Continued)

Menu	Item	Available Options
------	------	-------------------

ESCP2 * (Continued)	Auto CR	ON, OFF
	Auto LF	OFF, ON
	Bit Image	Dark, Light, BarCode
	Zero Char	0, ϕ
FX*	Font	Courier, Prestige, Roman, Sans serif, Script
	Pitch	10 CPI, 12 CPI, 15 CPI, Prop
	Condensed	OFF, ON
	T-Margin	0.40 to 1.50 Inch (0.05 steps)
	Text	1 to (available) lines
	CG Table	Pc USA, Italic, PcMultilin, PcPortuguese, PcCanFrenc, PcNordic, PcTurk2, Pc.E.Europe, BpBRASCII, BpAbicomp
	Country	USA, France, Germany, UK, Denmak, Sweden, Italy, Spain1, Japan, Norway, Denmark2, Spain2, LatinAmerica
	Auto CR	ON, OFF
	Auto LF	OFF, ON
	Bit Image	Dark, Light, BarCode
	Zero Char	0, ϕ
I239X*	Font	Courier, Prestige, Gothic, Orator Script, Presentor
	Pitch	10 CPI, 12 CPI, 15 CPI, 17 CPI, 20 CPI, 24 CPI, Prop
	Code Page	437, 850, 860, 863, 865
	T-Margin	0.40 to 1.50 Inch (0.05 steps)
	Text	1 to (available) lines
	Auto CR	OFF, ON
	Auto LF	OFF, ON
	Alt.Graphics	OFF, ON
	Bit Image	Dark, Light, BarCode
	Zero Char	0, ϕ

* With option

Table 1-12. Printer Settings (Continued)

Menu	Item	Available Options
JOB	PAGE PROTECT	AUTO, ON
	RESOLUTION	600, 300
	IMAGE OPTIMUM	AUTO, OFF, ON
	TIMEOUT	5 to 300
EMULATION	PARALLEL	LJ4, ESCP2*, FX*, I239X*, PS*, GL2, AUTO*
	SERIAL*	LJ4, ESCP2*, FX*, I239X*, PS*, GL2, AUTO*
	L/T*	LJ4, ESCP2*, FX*, I239X*, PS*, GL2, AUTO*
	AUX*	LJ4, ESCP2*, FX*, I239X*, PS*, GL2, AUTO*
CONFIG	AUTO CONT	OFF, ON
	STANDBY	ENABLE, DISABLE
	DENSITY	3, 4, 5, 1, 2
	INTERFACE	AUTO, PARALLEL, SERIAL*, L/T*, AUX*
	TOP OFFSET	0 to 99
	LEFT OFFSET	0 to 99
	PAGE COUNT	0 to 262143
PARALLEL	SPEED	FAST, LOW
	BI-D	ON, OFF
SERIAL	WORD LENGTH	8, 7
	BAUD RATE	9600, 19200, 38400, 57600, 300, 600, 1200, 2400, 4800
	PARITY	NONE, EVEN, ODD
	STOP BIT	1, 2
	DTR	ON, OFF
	XON/XOFF	ON, OFF
TEST	STATUS SHEET	—
	PS STATUS SHEET*	—
	PS FONT SAMPLE*	—
	PS FACT SHEET*	—
	EXT PRINTER INFO	—

* With option

1.4.3 Service Mode

This printer has the following four service modes:

- Hexadecimal dump mode
- EEPROM format mode
- Factory reset mode
- Default setting mode

Each service mode can be activated selectively, by turning the printer on while hold down the button and release it at the corresponding timing shown in table below.

Table 1-13. Service Mode Select Timing

Order	Pattern	LED (Yellow)	LED (Red)	Mode
1	Pattern 0-0	ON	ON	NA
2	Pattern 0-1	OFF	OFF	NA
3	Pattern 1	ON	OFF	Hexadecimal dump mode
4	Pattern 2	OFF	ON	EEPROM Initialize mode
5	Pattern 3	ON	OFF	Factory reset mode
6	Pattern 4	OFF	OFF	Default setting mode *1

*1: Can be performed by the user.

1.4.3.1 Hexadecimal Dump Mode

Hexadecimal dump mode is a useful tool in troubleshooting data control problems. To enter hexadecimal dump mode, release the button at the mode select timing "Pattern-1". To quit the hexadecimal dump mode, turn off the printer or perform the warm-boot operation.

1.4.3.2 EEPROM Initialize Mode

EEPROM initialize operations are required only when the main board or EEPROM is replaced and these operations are specified in the accompanying documentation.

This mode resets all user settings to the factory default settings and clears the printer status information (page counter and jam counter). To perform EEPROM initialize mode, release the button at the mode select timing "Pattern-2" and press the button again within 2 seconds from the release. The LED lights flashes alternately during the initialization. If the button is not pressed within 2 seconds after release, the printer enters normal state without initialize operation.

1.4.3.3 Factory Reset Mode

The factory reset mode resets the printer settings to the factory default settings (the page counter and jam counter are not cleared). To enter factory reset mode, release the button at the mode select timing "Pattern-3" and press the button again within 2 seconds after release. The LED lights flashes alternately during the reset operation. If the button is not pressed within 2 seconds after release, the printer enters the normal state without reset operation.

1.4.3.4 Default Settings

The default settings function is used to enter printer settings. The procedure for entering default settings is:

1. To enter the default settings mode, turn on the printer while holding down the button until yellow and red lights turn off and on and off.
2. Press the button the number of times for the 1st code, while the yellow light is flashing.
3. Press the button the number of times for the 2nd code, while the red light is flashing.
4. Press the button the number of times for the 3rd code, while all lights flash.
5. If you need end the default settings mode, return step 2 and input the "111" code.
If you need set the other settings, return to step 2.

Table 1-14 shows default settings codes.

Table 1-14. Default Settings Codes

Menu	Item	Available Options	Default Settings Codes		
			1st Code	2nd Code	3rd Code
End of default settings mode			1	1	1
PARALLEL	SPEED	FAST	1	1	2
		SLOW	1	1	3
	Bi-D	ON	1	1	4
		OFF	1	1	5
SERIAL*	WORD LENGTH	8	1	2	1
		7	1	2	2
	BAUD RATE	9600	1	2	3
		19200	1	2	4
		38400	1	2	5
		27600	1	3	1
		300	1	3	2
		600	1	3	3
		1200	1	3	4
		2400	1	3	5
		4800	1	4	1
	PARITY	NONE	1	4	2
		EVEN	1	4	3
		ODD	1	4	4
	STOP BIT	1	1	4	5
		2	1	5	1
	DTR	ON	1	5	2
		OFF	1	5	3
	XON/XOFF	ON	1	5	4
		OFF	1	5	5

* With option

Table 1-14. Default Settings Code (Continued)

Menu	Item	Available Options	Default Settings Codes		
			1st Code	2nd Code	3rd Code

EMULATION	PARALLEL	LJ4	2	1	1
		ESCP2*	2	1	2
		FX*	2	1	3
		I239X*	2	1	4
		PS*	2	1	5
		GL2	2	2	1
		AUTO*	2	2	2
	SERIAL*	LJ4	2	3	2
	LT*				
	AUX*				
	SERIAL*	ESC/P2*	2	3	3
	LT*				
	AUX*				
	SERIAL*	FX*	2	3	4
	LT*				
	AUX*				
	SERIAL*	I239X*	2	3	5
	LT*				
	AUX*				
	SERIAL*	PS*	2	4	1
	LT*				
	AUX*				
	SERIAL*	GL/2	2	4	2
	LT*				
	AUX*				
	SERIAL*	AUTO*	2	4	3
	LT*				
	AUX*				

* With option

Table 1-14. Default Settings Code (Continued)

Menu	Item	Available Options	Default Settings Codes		
			1st Code	2nd Code	3rd Code
ESC/P2* / FX*	CG Table	PcUSA	2	5	3
		Italic	2	5	4
		PcMultilin	2	5	5
		PcPortugue	3	1	1
		PcCanFrenc	3	1	2
		PcNordic	3	1	3
		PcTurkish	3	1	4
		PcE.Europe	3	1	5
		BpBRASCII	3	2	1
		BpAbicom	3	2	2
STATUS SHEET	LANGUAGE	ENGLISH	3	2	3
		FRENCH	3	2	4
		GERMAN	3	2	5
		ITALIAN	3	3	1
		SPANISH	3	3	2
PRINTING	PAGE SIZE	A4	3	5	1
		LT	3	5	2
		LGL	3	5	3
		CTM	3	5	4
	ORIENTATION	PORT	3	5	5
		LAND	4	1	1
	MANUAL FEED	OFF	4	1	2
		ON	4	1	3
TONER SAVER	OFF	4	1	4	
	ON	4	1	5	
JOB	RESOLUTION	600	4	2	1
		300	4	2	2
CONFIG	AUTO CONT	OFF	4	2	3
		ON	4	2	4
	STANDBY	ENABLE	4	2	5
		DISABLE	4	3	1
	INTERFACE	AUTO	4	3	2
		PARALLEL	4	3	3
		SERIAL	4	3	4
		LT	4	3	5
AUX	4	4	1		

* With option

1.4.4 Display of Messages

This printer indicates three types of messages with the LED lights or status sheet: status messages, error messages, and the service call error message.

1.4.4.1 Status Messages

The LED lights normally indicate the printer's status. (Refer to Section 1.4.1.)

1.4.4.2 Error Messages

If any of the following errors occurs, it will be printed on the status sheet (Refer to Section 1.4.2.). Clear the error immediately using the measures shown in the following table.

Table 1-15. Error Messages

Message	Status	Measures
SOFT ERROR	Printer detected a CPU error or soft error. (Refer to Chapter 5.)	—
PAPER JAM	A paper jam has occurred.	Open the cover and remove the jammed paper. Then close the cover.
PRINTER OPEN	Cover is open.	Close the cover.
MANUAL FEED	Select manual feed and begin printing data.	Insert paper and press button.
PAPER SET	No paper is left in either the standard tray or the optional cassette.	Load paper in paper tray or optional cassette and press button.
PRINT OVERRUN	Engine speed faster than print image processing.	Press the button.
MEM OVERFLOW	Data has filled the buffer.	Confirm and press the button. And add optional SIMM.
CHECK PAPER SIZE	The paper size in the tray is different from the paper size chosen.	Change the paper and print again.
IMAGE OPTIMUM	The printer uses a lower print quality.	Erase downloaded data or add a SIMM.

1.4.4.3 Service Call Error Message

The LED lights flash randomly, when the printer detects a service call error. (Refer to Chapter 5.).

1.4.5 Printer Sharing

This section describes printer sharing. This printer has two methods of printer sharing, port fixed mode and auto sense mode. These modes are selected by "INTERFACE" in the printer settings menu.

1.4.5.1 Port Fixed Mode

When the printer is in port fixed mode, only one interface port is active. Data from other ports is ignored.

1.4.5.2 Auto Sense Mode

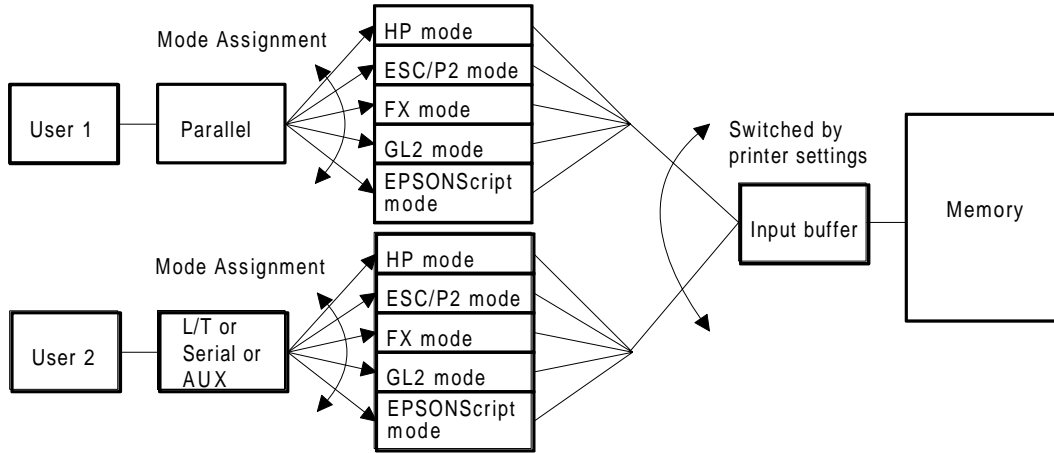

Figure 1-10. Port Fixed Mode

It is possible to allocate each mode to parallel, serial, L/T, and AUX. The entire memory will be allocated to the channels that are used. The interface that receives the data first will print first.

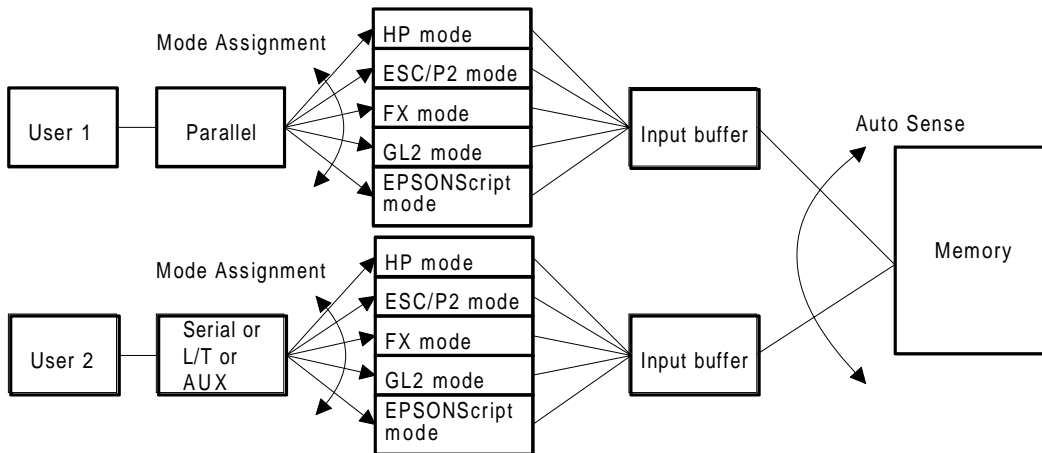

Figure 1-11. Auto Sense Mode

1.4.6 Emulation Mode Switch Function

This section describes the emulation mode switch function.

1.4.6.1 Emulation Switch by SPL

The two types of emulation switch function described below are available on this printer. Together they are referred to as SPL (Shared Printer Language).

EJL: EPSON Job Language

This is EPSON's original language system. It is used to skip among various destinations, as shown in Figure 1-12.

PJL: Printer Job Language

This is HP's original language, which is available with LaserJet 4 printer. It is used to skip among various destinations, as shown in Figure 1-12. The precise specifications for this language are based on HP LaserJet 4.

The figure below shows three types of mode switching.

Neither EJL nor PJL switches the mode directly. They first exit the current mode and return to EJL or PJL. Then they enter another mode.

1.4.6.2 Intelligent Emulation Switch

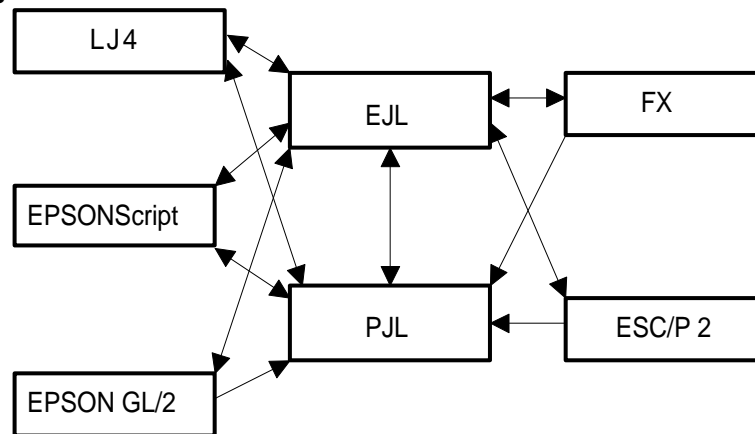

Figure 1-12. Emulation Switch by SPL

Intelligent Emulation Switch (IES) automatically switches emulation mode, depending on the data sent from the host computer through one of the interface channels. It is able to switch between EPSONScript and other modes as shown in the figure below.

1.4.7 Bi Resolution Improvement Technology

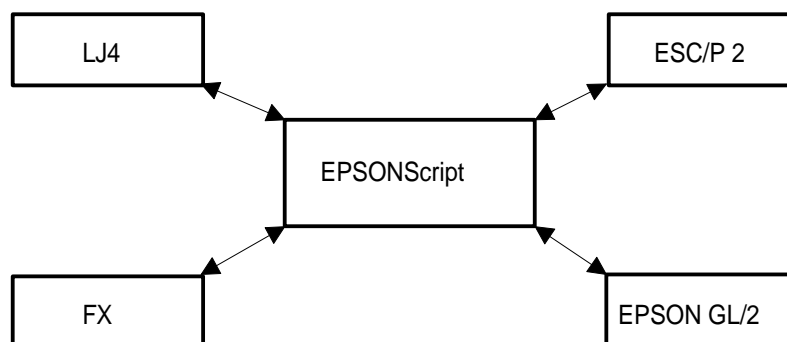
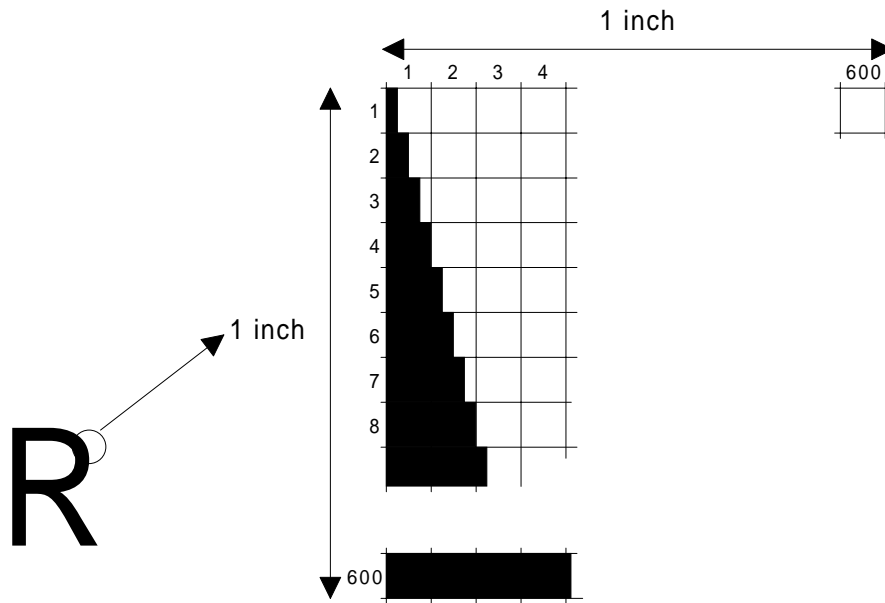

Figure 1-13. Intelligent Emulation Switch

The EPL-5500 printer has BiRITech (Bi Resolution Improvement Technology), which is designed to improve print quality at 600 dpi and 300 dpi. By this method, the dot map data extracted from the image data is reassembled to improve print data.

The main improvement of this technique is in eliminating “jaggies” in diagonal lines. It is most effective when the dot map data fits the development characteristics of the printer mechanism well. It is therefore necessary to set appropriate values in printer settings.

Note: BiRITech is not as effective for printing a mesh pattern or gray scale. In such cases, BiRITech must be set to OFF. (The default setting is MEDIUM.) Since the BiRITech effect depends on the toner condition, adjusted it when the imaging cartridge is replaced or after the imaging cartridge is used for a long time.



(When 600 DPI printing)

Figure 1-14. Effect of BiRITech

The following settings are available in printer settings for RITech: DARK, MEDIUM, LIGHT, OFF. The status sheet has the following RITech test image. When the toner density of area A is almost the same as that of area B (as shown in the figure below), the RITech setting is at its optimum setting. In other words, the optimum setting is achieved when it is difficult to distinguish the shape of area A from that of B.

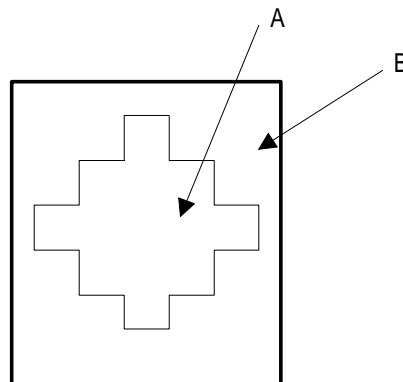

Figure 1-15. RITech Adjustment

1.4.8 Toner Save Mode

The Toner Save Mode uses about 50% less toner than normal. The printer saves toner by substituting a gray shade for the black inside of characters. the outlines of the characters are still printed in full black.

1.4.9 Optional Memory

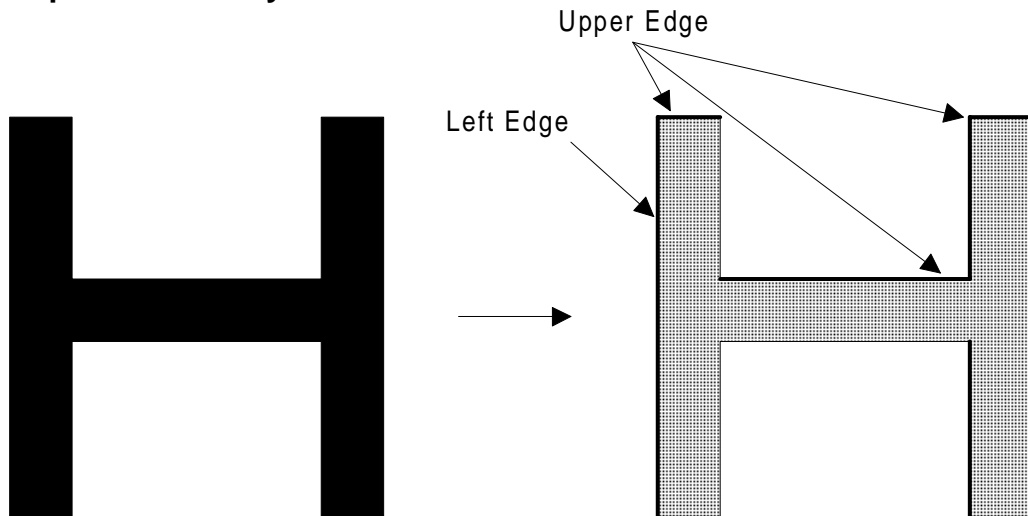

Figure 1-16. Toner save Mode

If you have difficulty printing complex, graphics-intensive pages or if you regularly use downloaded fonts, you may need to install one of the optional SIMM sets on this printer's controller board. The printer's controller board comes with 1MB of RAM installed.

By installing additional SIMMs, you can increase the printer's memory to a total of 32MB, including the resident memory.

EPSON supplies several types of memory option (SIMMs). Other SIMMs can be purchased from other vendors. Be sure the SIMM meets the requirements listed below.

- 72-pin type
- Capacity is one of the following: 1, 2, 4, 8, 16, 32MB
- Access speed is less than 70 ns.
- Within the following dimensional size
36 mm (height) × 108 mm (width) × 10 mm (depth)

1.5 MAIN COMPONENTS

To simplify maintenance and repair, the main components of the EPL-5500 have been designed for easy removal and replacement. The main components are:

- ❑ C169 MAIN-B Board Main board
- ❑ PWB-E Board Power supply circuit board
- ❑ PWB-F Board High-voltage supply circuit board
- ❑ Optical Unit Printhead unit
- ❑ Fusing Unit
- ❑ Photoconductor unit
- ❑ Developer cartridge
- ❑ Housing

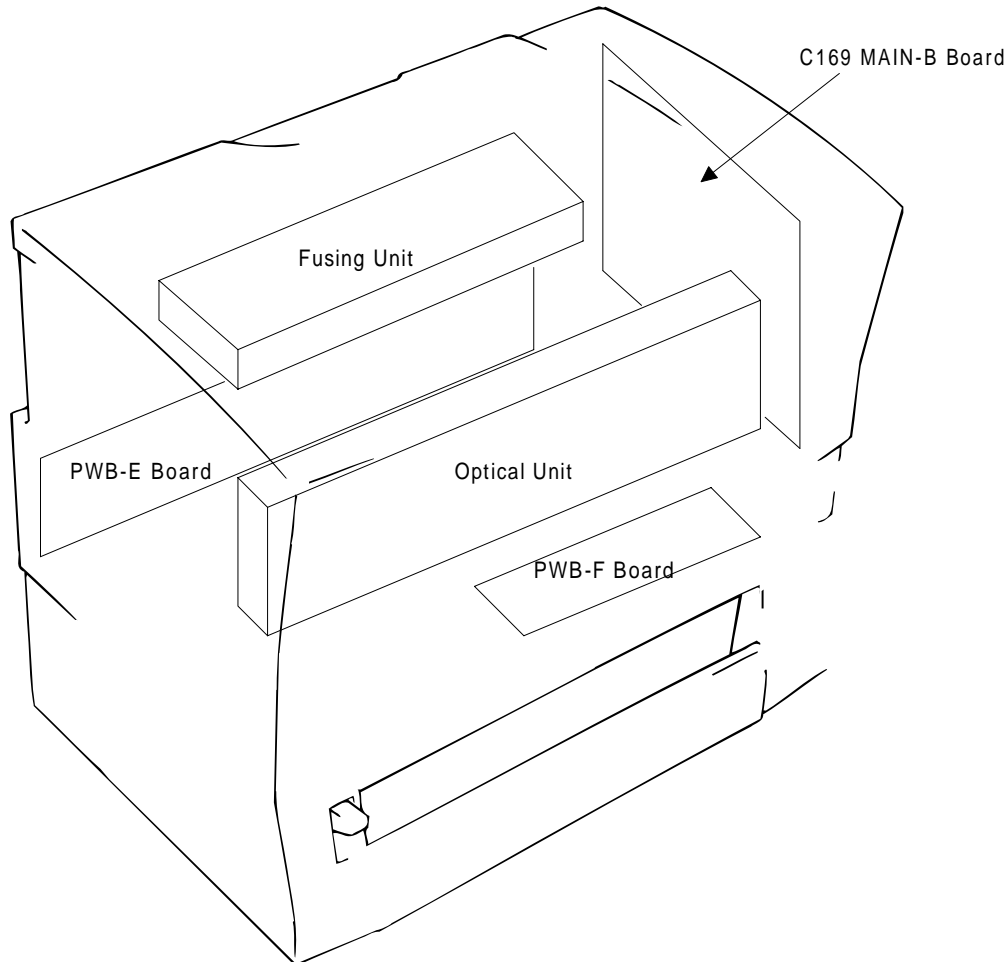

Figure 1-17. Component Layout

1.5.1 C169 MAIN-B Board

The C169 MAIN-B board is a video controller and engine controller board. The primary functions of this board are receiving print data from the host, generating the print image (video), and sending the print image to the engine controller via the video interface. A 32-bit 22 MHz RISC MB86933H SPARKlite CPU in location IC1 is used, and the following memory chips and custom ICs are assigned to the 4GB memory space.

❑ Memory chips

Code and font ROMs: four 4M-bit EPROMs (IC13, 14, 15, 16) or two 8M-bit mask ROMs (IC21, 22)

Optional NLSF font ROM: 4M-bit or 8M-bit ROM (IC12). Not available in U.S. version.

4M-bit DRAMs (IC17, 18)

EEPROM (IC11)

❑ Custom ICs

ASIC E05A91 (IC2)

ASIC E05A92 (IC3)

ASIC E05A93 (IC4)

❑ Others

Reset IC M51953BFP (IC6)

The engine controller consists of an M3807x 8-bit CPU, including a MASK ROM. It controls laser scanning (the polygon mirror drive motor), image synchronization, laser beam pulse width, and power.

There are two types of C169 MAIN-B boards used as after service parts. The following table shows differences between them.

Table 1-16. Differences in Components for the C169 MAIN-B Board

	US version	Other Version
IC12	None	IC socket
Jumper J20	Open	Short

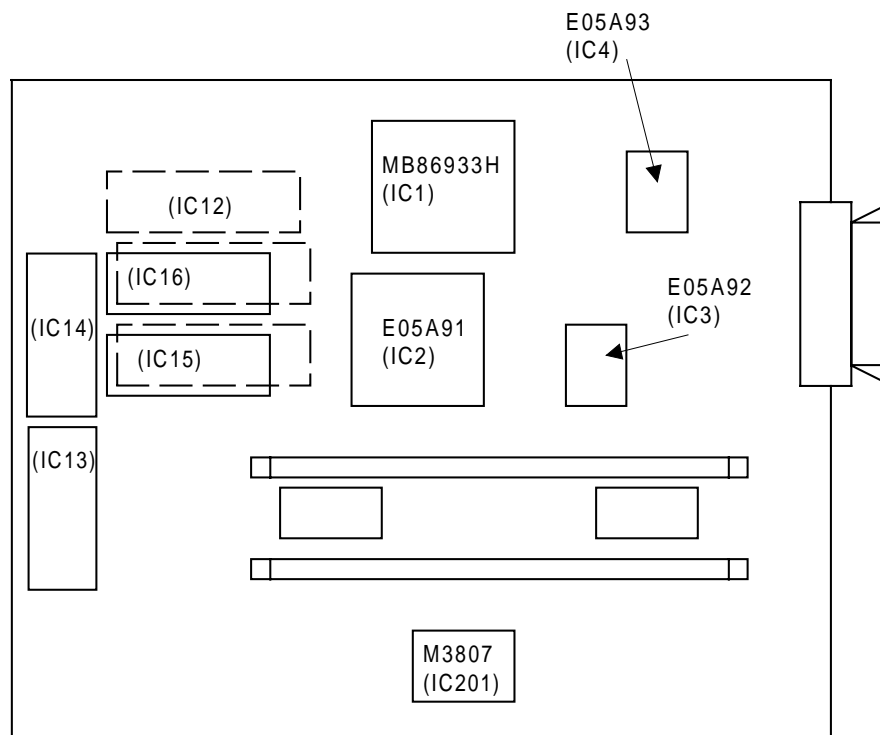

Figure 1-18. C169 MAIN-B Board

1.5.2 PWB-E Board

The PWB-E is the power supply board, which consists of a switching regulator circuit. It converts the AC line voltage into +24 V and +5 VDC voltages. There are two types of power supply board, the 100/120 V type and 220/240 V type. The difference between the two circuits is only in the input section.

CAUTION

Do not touch VR1 on PWB-E board. This volume is for factory setting only.

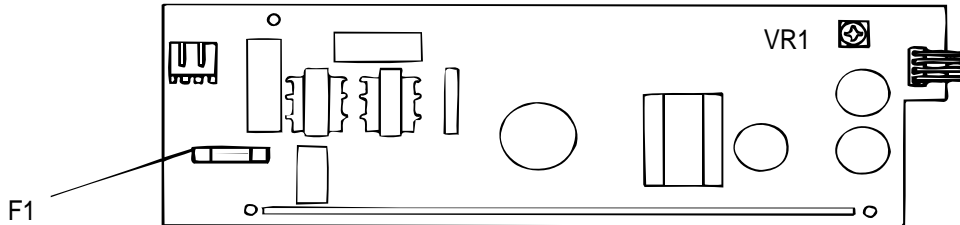

Figure 1-19. PWB-E Board

1.5.3 PWB-F Board

The PWB-F is the high-voltage supply circuit board. It converts the development bias, OPC drum charge bias, and image transfer bias.

CAUTION

Do not touch VR3 on the PWB-F board. These volumes are for factory setting only.

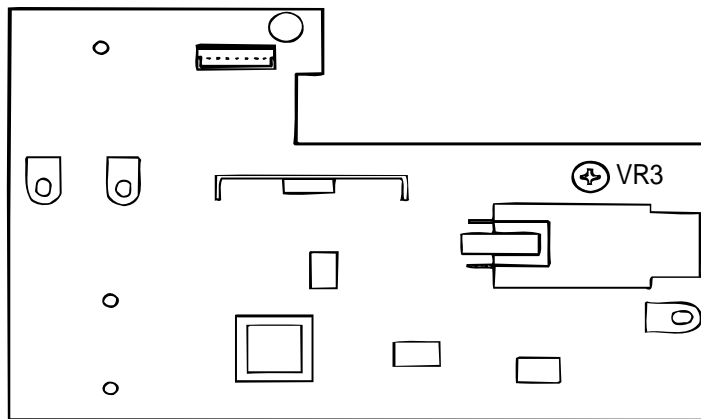

Figure 1-20. PWB-F Board

1.5.4 Optical Unit

The optical unit consists of the laser diode (semi-conductor laser), the mirror motor (scanner motor) which drives the polygon mirror for laser scanning, and several mirrors and lenses. The laser beam generated by the laser diode is conducted to the OPC drum surface by way of the polygon mirror, as well as several mirrors and lenses, to create a latent electro-photographic image on the drum.

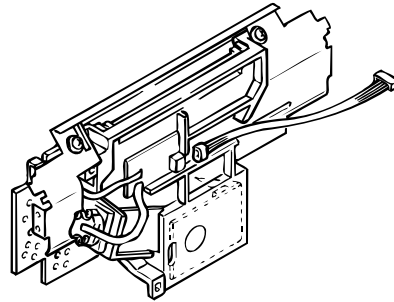

Figure 1-21. Optical Unit

1.5.5 Fusing Unit

The fusing unit fixes the toner to the paper using heat and pressure. This unit has a heater lamp, thermistor, and thermal fuse. There are two types of fusing units, the 120 V type and the 220/240 V type. The only difference between them is the heater lamp.

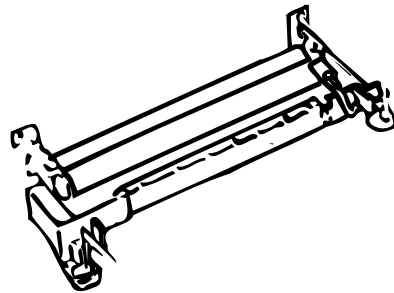

Figure 1-22. Fusing Unit

1.5.6 Photoconductor Unit

Core mechanisms of the printing process, such as charging and imaging, are integrated into this unit.

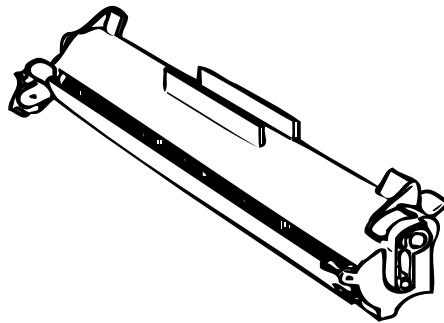

Figure 1-23. Photoconductor Unit

1.5.7 Developing Cartridge

Core mechanisms of the printing process, such as developing, are integrated into this cartridge.

1.5.8 Lower Paper Casste Unit

This optional paper cassette allows you to feed up an additional 250 sheets of A4 or B5 paper into this printer.

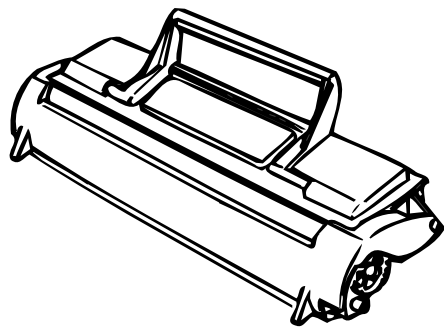

Figure 1-24. Developing Cartridge

Note: While you use A4/B5 paper, jumper JP1 on the circuit board of lower paper casste unit should be set to 2-3. While you use letter/ executive paper, jumper JP1 should be set to 1-2. Jumper JP2 is fixed to 1-2.

Chapter 2 Operating Principles

Table of Contents

2.1 ENGINE OPERATION	2-1
2.1.1 Print Process	2-2
2.1.1.1 Paper Feeding	2-3
2.1.1.2 Drum Charge	2-4
2.1.1.3 Laser Exposure	2-5
2.1.1.4 Development	2-5
2.1.1.5 Image Transfer	2-6
2.1.1.6 Fusing	2-6
2.1.2 Engine Control	2-7
2.1.2.1 Main Motor Functions and Control	2-8
2.1.2.2 Paper Take-Up Sensor and Paper Exit Sensor	2-9
2.1.2.3 Fuser Control	2-10
2.1.2.4 Scanner Mirror Motor Control	2-11
2.1.2.5 Laser Diode Drive	2-12
2.1.2.6 Bias Voltages and Laser Drive Timing	2-13
2.1.2.7 Fan Motor Control	2-15
2.1.2.8 Power Supply Circuit Function and Safety Protection	2-15
2.2 VIDEO CONTROLLER OPERATION	2-16
2.2.1 C169 MAIN-B Board Operation	2-16
2.2.1.1 Reset Circuit	2-19
2.2.1.2 Bus Control Circuit	2-19
2.2.1.3 Interrupt Control	2-20
2.2.1.4 DRAM Management	2-20
2.2.1.5 Parallel Interface Circuit	2-21
2.2.1.6 Video Interface	2-22

List of Figures

Figure 2-1. Main Components	2-1
Figure 2-2. Print Process Diagram	2-2
Figure 2-3. Paper Feeding from the Paper Feed Tray	2-3
Figure 2-4. Paper Feeding from the Lower Paper Cassette	2-4
Figure 2-5. Drum Charge	2-4
Figure 2-6. Laser Exposure	2-5
Figure 2-7. Development	2-5
Figure 2-8. Image Transfer	2-6
Figure 2-9. Fusing	2-6
Figure 2-10. Engine Controller Connecting Diagram	2-7
Figure 2-11. Gear and Roller Positions	2-8
Figure 2-12. Main Motor Drive Circuit	2-9
Figure 2-13. Paper Take-Up Sensor and Paper Exit Sensor On/Off Timing	2-9
Figure 2-14. Fuser Control Circuit	2-10
Figure 2-15. Temperature for Fuser Control Procedure	2-10
Figure 2-16. Scanner Motor Control Circuit	2-11
Figure 2-17. Laser Diode Drive Circuit	2-12
Figure 2-18. LDATA Generation Circuit	2-12
Figure 2-19. Laser Emission Power Adjustment Timing	2-12

Figure 2-20. High-Voltage Supply Block Diagram	2-13
Figure 2-21. Print Process	2-14
Figure 2-22. Print Sequence (Start)	2-14
Figure 2-23. Print Sequence (End)	2-14
Figure 2-24. Power Supply Circuit Block Diagram	2-15
Figure 2-25. Video Controller Section	2-16
Figure 2-26. C169 MAIN-B Board Block Diagram	2-16
Figure 2-27. Data Flow Diagram	2-18
Figure 2-28. Reset Circuit	2-19
Figure 2-29. Bus Control Circuit	2-19
Figure 2-30. DRAM Management	2-20
Figure 2-31. Parallel Interface Circuit	2-21

List of Tables

Table 2-1. Functions of C169 MAIN-B Board Main Elements	2-17
---	------

2.1 ENGINE OPERATION

This section describes the functions and operating principles of the EPL-5500 engine. Figure 2-1 shows the locations and names of the main engine components.

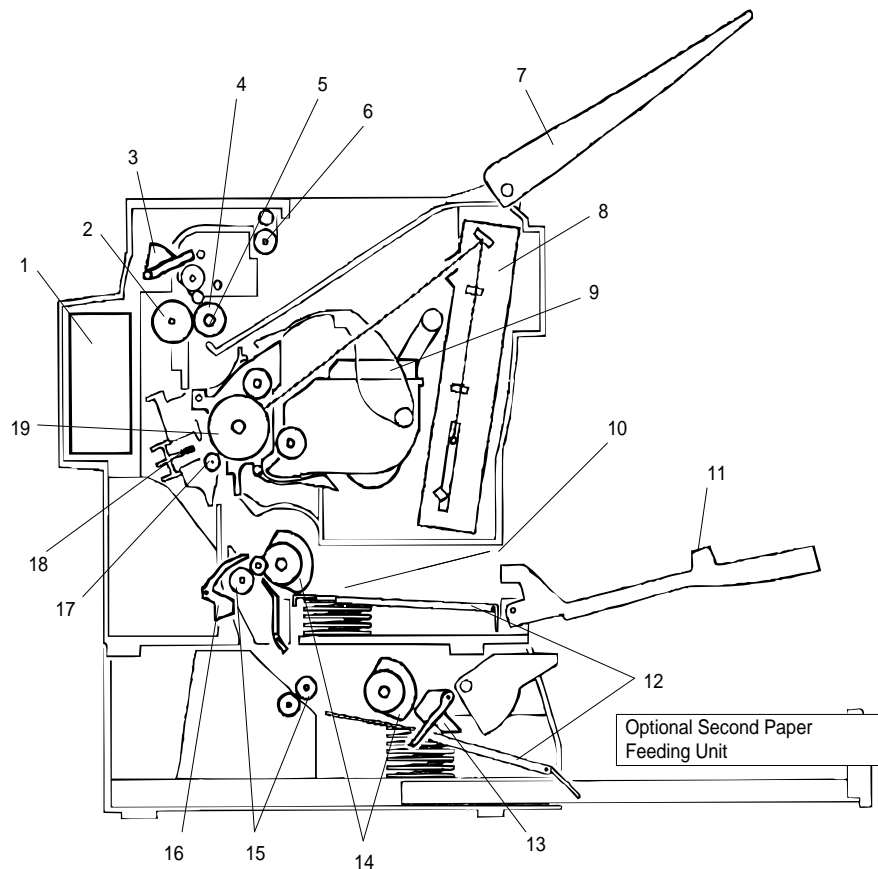

Figure 2-1. Main Components

- | | |
|----------------------------|--------------------------------|
| 1. Fan Motor (M3) | 11. Paper Feeding Tray |
| 2. Lower Fusing Roller | 12. Paper Lift-up Plate |
| 3. Paper Exit Sensor (PC3) | 13. Paper Empty Sensor (PI1) |
| 4. Upper Fusing Roller | 14. Paper Take-up Roller |
| 5. Heater Lamp (H1) | 15. Paper Transport Roller |
| 6. Paper Exit Roller | 16. Paper Take-up Sensor (PC1) |
| 7. Print Tray | 17. Pre-image Transfer Roller |
| 8. Optical Unit | 18. Electrode Comb |
| 9. Toner Cartridge | 19. Drum Cartridge |
| 10. Manual Feed Guide | |

2.1.1 Print Process

This section describes the print process from paper feeding to paper exit. Figure 2-2 shows a diagram of the print process.

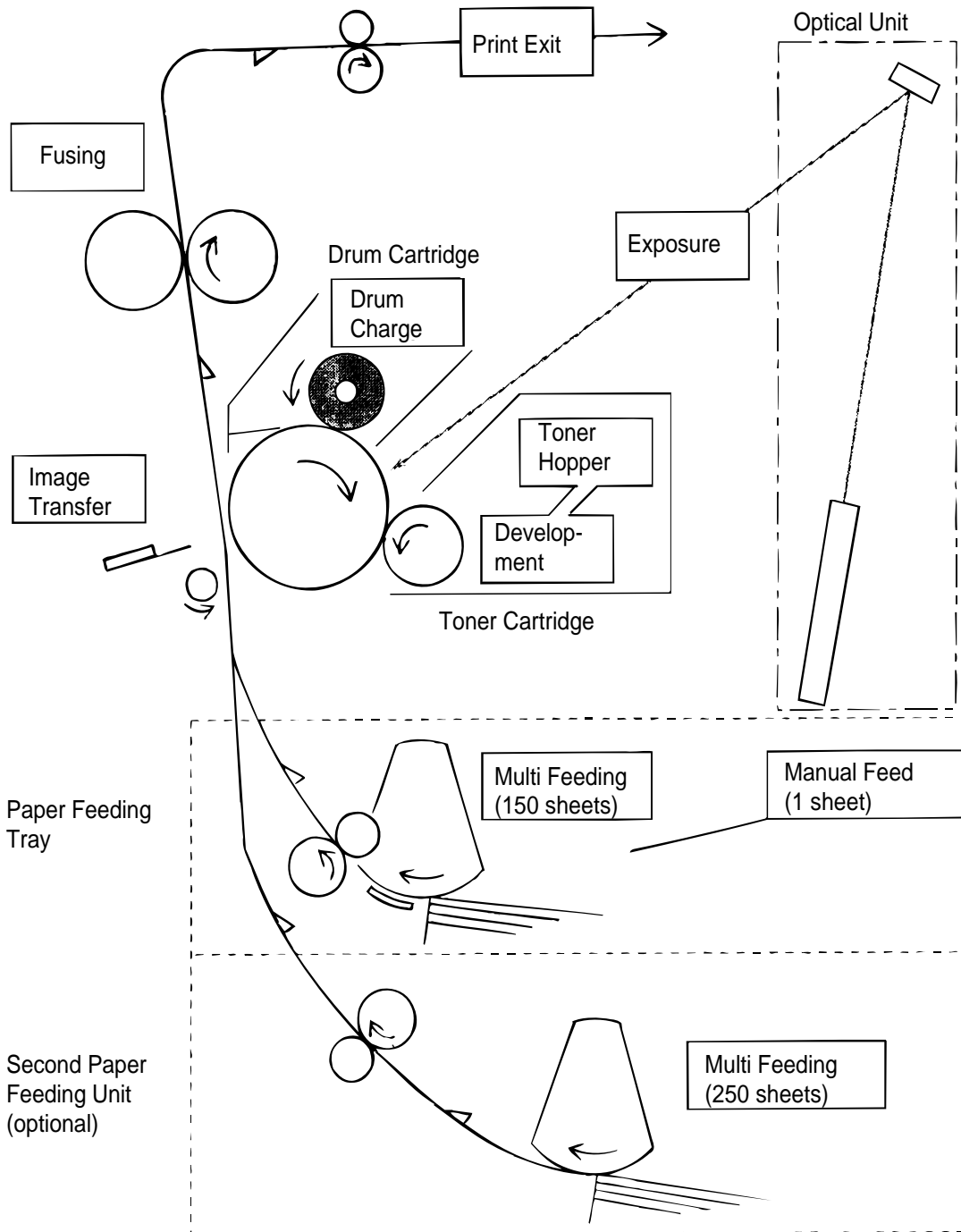

Figure 2-2. Print Process Diagram

2.1.1.1 Paper Feeding

Paper can be fed into the printer from the paper feed tray (150 sheets) or from the manual feed slot (1 sheet at a time). Installing an optional second paper feed unit (lower cassette, 250 sheets) adds another feeding method. Paper fed by the paper take-up roller is transported to the transport roller, pre-image transfer roller, and then exit roller. After this, the paper is fed out onto the print tray. The starting position of an image is decided by the paper take-up sensor (PC1). A photo sensor is used as the paper take-up sensor (PC1) and the paper exit sensor (PC3).

Paper Feeding Tray (Standard Tray)

When the paper take-up solenoid is energized, the main motor (M1) drive is transmitted to the paper take-up roller via the paper take-up clutch (a one-way clutch) to rotate the paper take-up roller one revolution. At the same time, the depression cam rotates and releases the paper lift-up plate to feed the top (first) paper. The fixed separating pad is used for the paper separation system. It prevents the second or later sheets from being fed together with the top paper.

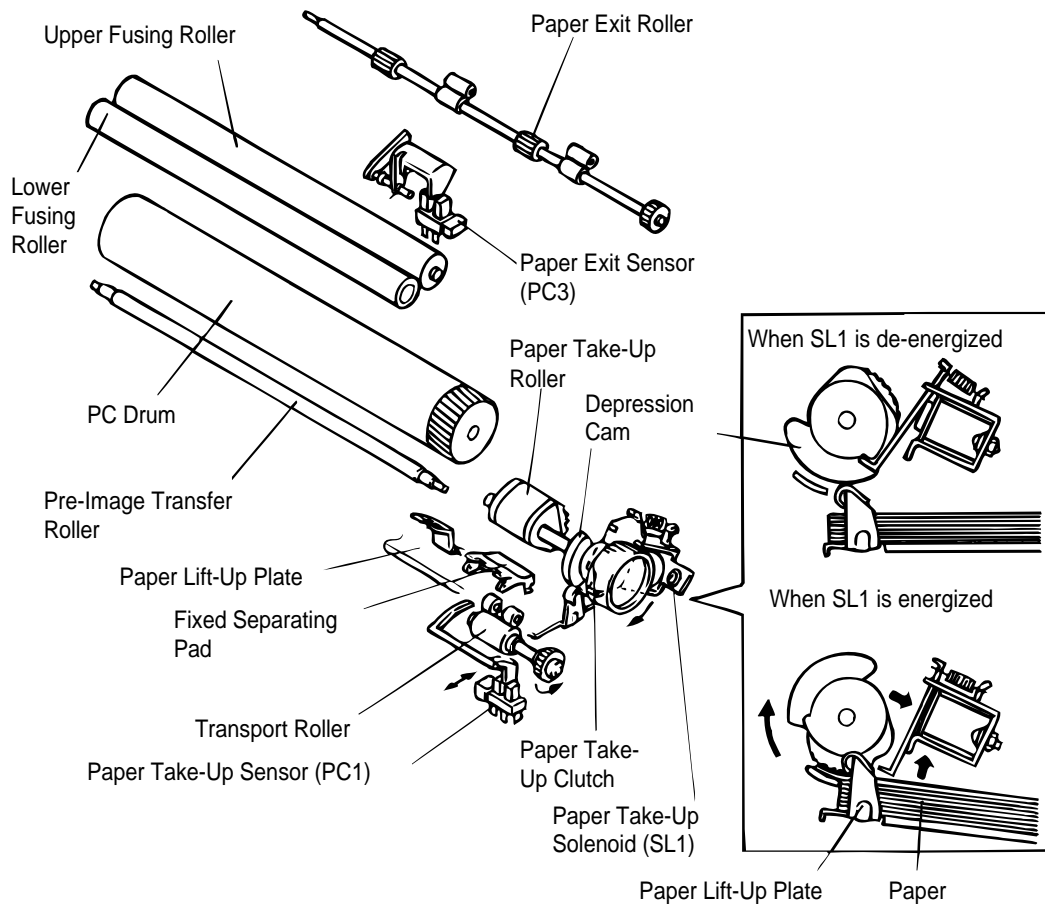

Figure 2-3. Paper Feeding from the Paper Feed Tray

Second Paper Feed Unit (Optional Lower Cassette)

This unit contains no drive motor, so the main motor (M1) drive is transmitted to the paper take-up and transport sections in the unit via the drive transmission gear. Although the feeding method is the same as for the paper feed tray in the printer, this unit uses a corner separation system as its paper separating function. The paper take-up solenoid in the lower cassette is controlled by the printer via a circuit board in the optional unit.

When the paper regulation plate is set to the inside position, switch S1 on the circuit board is automatically turned on, causing the printer to recognize that B5-size paper will be fed. On the other hand, when the paper regulation plate is set to the outside position, S1 remains off, causing the printer to recognize that A4-size paper will be fed.

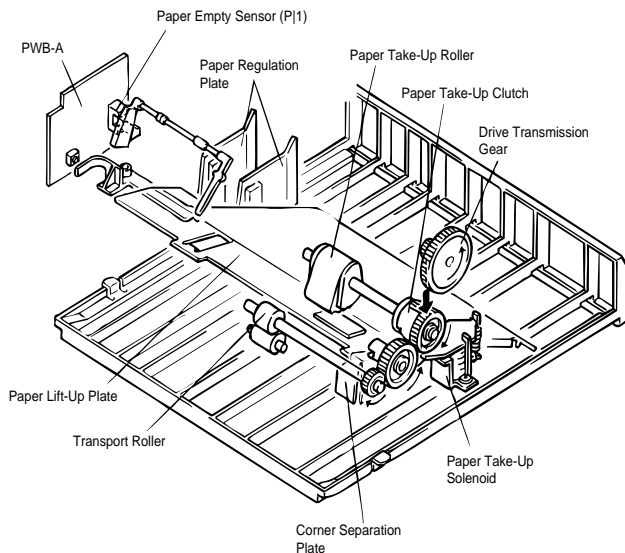

Figure 2-4. Paper Feeding from the Lower Paper Cassette

2.1.1.2 Drum Charge

The PC drum is charged with static electricity before laser exposure. The rotating charge brush and pre-film are used as the charging method. Less ozone is generated by the corona charge of the rotating charge brush and the pre-film, and the PC drum can be charged with low voltage because the charge is directly applied to the PC drum. The rotating charge brush is rotated by the drive of the M1 main motor via its gear.

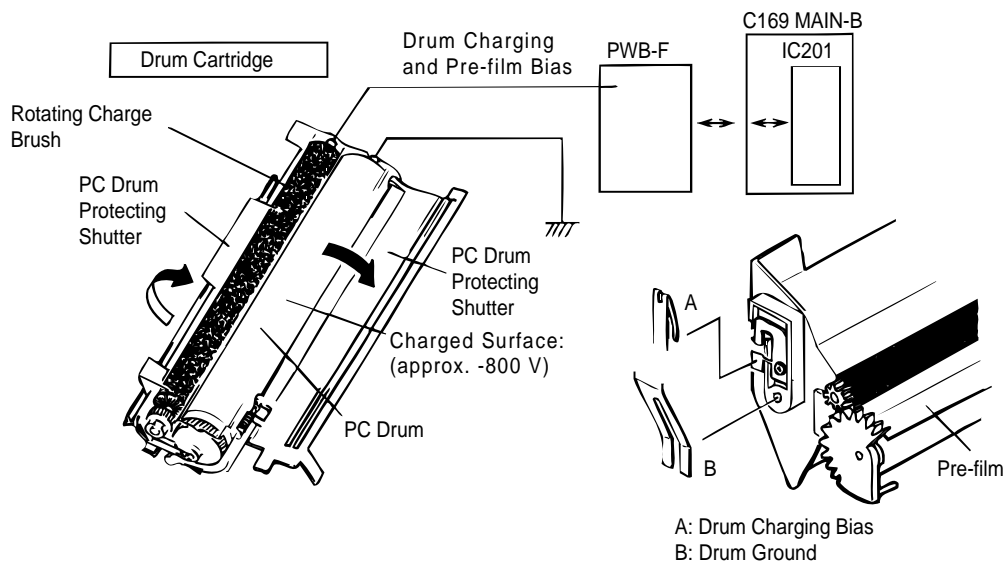

Figure 2-5. Drum Charge

2.1.1.3 Laser Exposure

The laser beam, emitted from the optical unit, makes an invisible static image. The SOS (start of scan) sensor, installed on the laser diode control board (PWB-D), unifies the laser emission timing for each scan line.

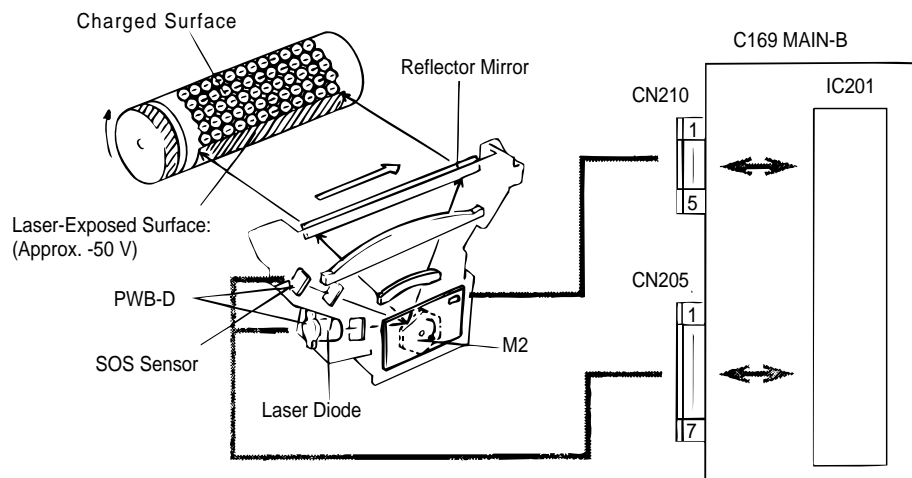

Figure 2-6. Laser Exposure

2.1.1.4 Development

Toner is applied to the invisible static image on the PC drum and a toner image is created on the surface. When the PC drum starts to rotate (when the main motor is activated), the PC drum surface remains 0 V at the position between the rotating charge brush and sleeve roller. At this time, a specified positive voltage is applied to the sleeve roller to prevent toner from being attracted back onto the PC drum (reverse bias control).

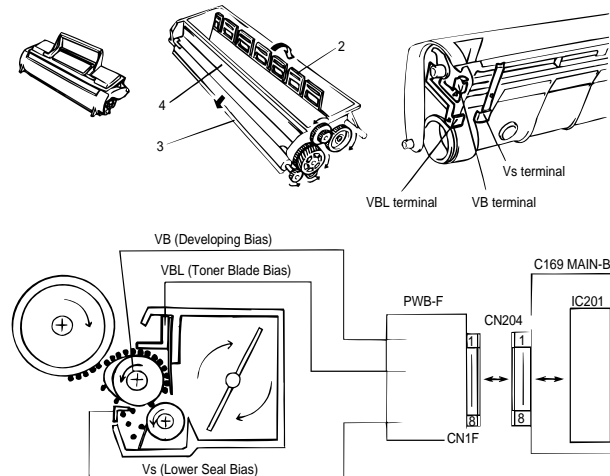

Figure 2-7. Development

1. Toner hopper: Contains toner.
2. Toner agitating screw: Stirs the toner in the hopper and sends the toner to the toner transport roller.
3. Toner transport roller: Transports the toner to the sleeve roller.
4. Doctor blade: Spreads a thin, even coat of toner over the resin sleeve. The toner is negatively charged by passing between this blade and resin sleeve.
5. Sleeve roller: Rotates the resin sleeve.
6. Resin sleeve: Carries the toner to the PC drum surface for development.
7. Bias seal: Collects the toner remaining on the resin sleeve.
8. PC drum: Is exposed to the laser to create an invisible image and rotates to carry the developed image to the paper surface.

2.1.1.5 Image Transfer

The electrode comb is an image transfer system that transfers the toner image on the PC drum onto the paper.

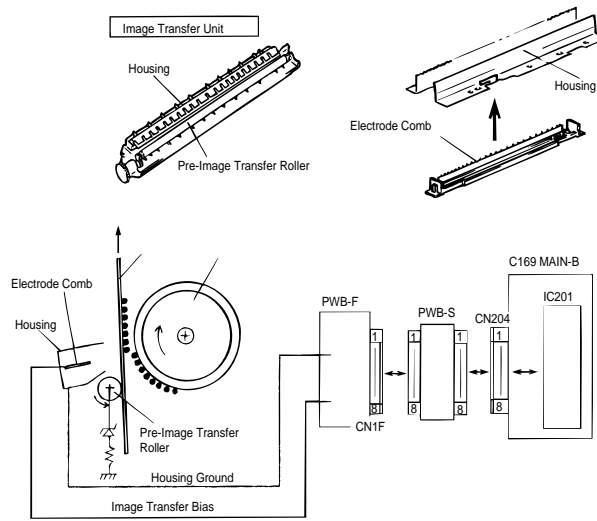

Figure 2-8. Image Transfer

2.1.1.6 Fusing

The toner image transferred onto the paper is fixed securely using a heat roller system as the fusing system. The upper fusing roller, which is heated by the heater lamp, fuses the toner image, which is securely fixed by the pressure between the upper and lower fusing rollers. Thermistor TH1 detects and controls the temperature of the upper fusing roller. Thermal fuse TF1 blows when the temperature exceeds 200° C, shutting down power to the heater lamp.

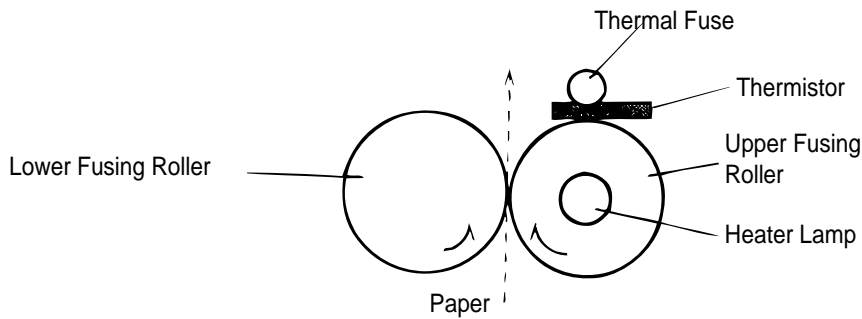

Figure 2-9. Fusing

2.1.2 Engine Control

This section describes engine control, the power supply board, and the high-voltage supply board. The engine is controlled by the main board (C169 MAIN-B Board). Figure 2-10 shows the engine controller connecting diagram.

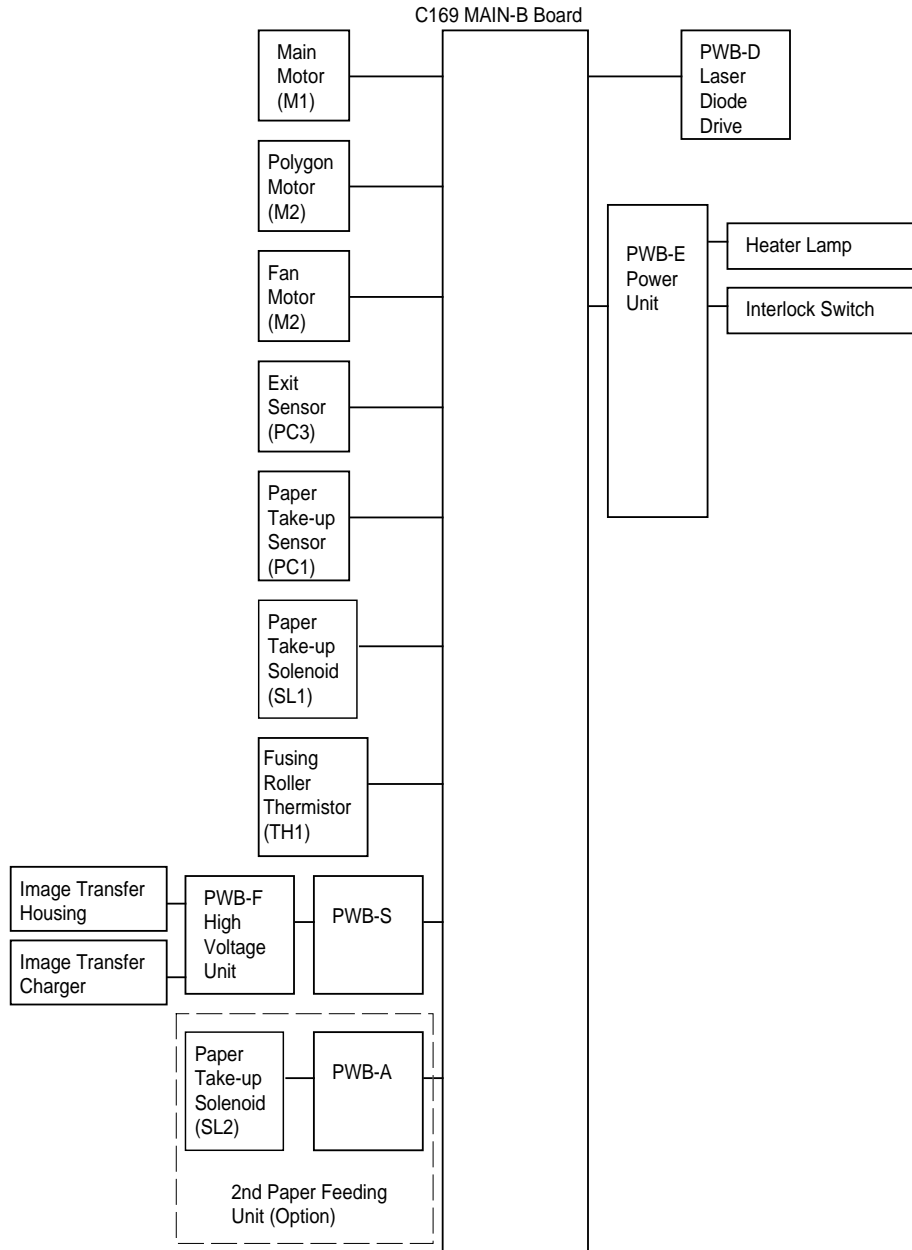

Figure 2-10. Engine Controller Connecting Diagram

2.1.2.1 Main Motor Functions and Control

The M1 main motor transmits the drive to the printer rollers and the optional second paper feed unit (lower cassette) via each gear as shown below.

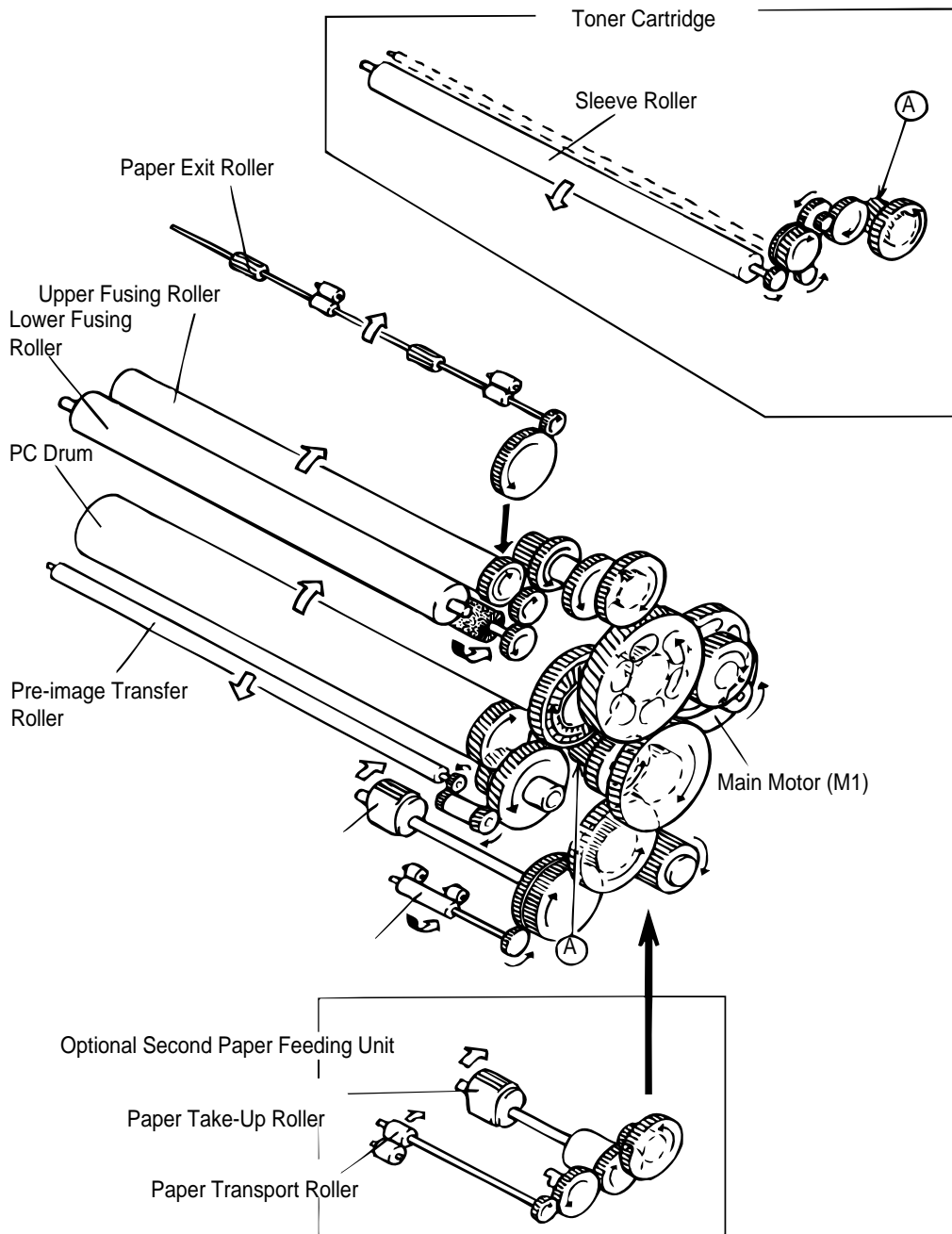

Fig.2-11. Gear and Roller Positions

Figure 2-12 shows the main motor drive circuit. The M1 main motor is a four-phase stepping motor controlled by the CPU (IC201) on the main board (C169 MAIN-B). This board has a stepping motor driver IC that drives the M1 main motor with a constant current.

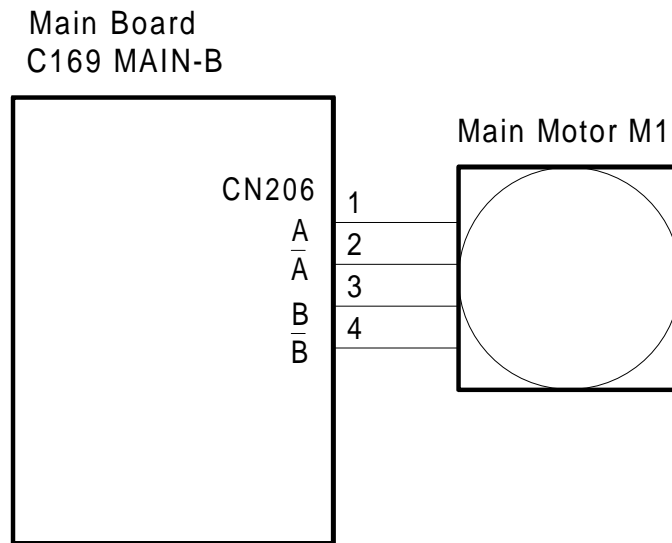

Figure 2-12. Main Motor Drive Circuit

2.1.2.2 Paper Take-Up Sensor and Paper Exit Sensor

The paper take-up sensor has three functions:

1. To detect the top edge of paper. The engine starts printing when the detection signal is received.
2. To detect paper size. The printer detects the time it takes for paper to pass the paper take-up sensor during paper feeding. If this time is long, longer paper is feeding; if the time is short, shorter paper is feeding.
3. To detect paper jams and feed jams.

If the paper take-up sensor does not turn on for paper feeding, the printer detects a feed jam or no paper. A feed jam is a paper jam that occurs in the feed process.

If any of the following conditions is detected, the printer detects a paper jam. A paper jam is a jam that occurs in the printing process area.

- The paper take-up sensor (PC1) or the paper exit sensor (PC3) is on at power on or when the upper case is closed.
- The paper take-up sensor (PC1) or the paper exit sensor (PC3) is not turned on/off within the specified time. (Refer to the following timing chart.)

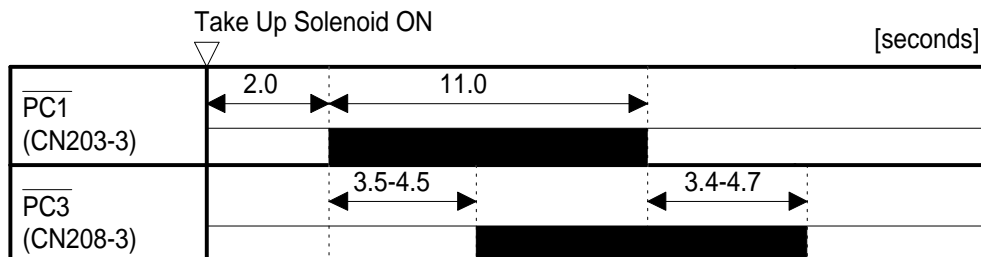

Figure 2-13. Paper Take-Up Sensor and Paper Exit Sensor On/Off Timing

2.1.2.3 Fuser Control

The heater lamp, powered by AC voltage, heats the fuser. When the power supply board receives a FUSER signal from the main board (C169 MAIN-B), the power supply board (PWB-E) supplies the AC voltage to the heater lamp. This AC voltage is cut by an interlock switch when the case is open.

Thermistor TH1 detects the surface temperature of the upper fusing roller and inputs that analog voltage to the 77-pin chip, IC201. Based on this temperature data, the heater lamp on/off signal (the FUSER signal) is output from the 54-pin chip, IC201, causing heater lamp H1 to turn on or off to control the fusing temperature. When the heater lamp is not turned off even if the thermistor detects a high temperature malfunction (which occurs if the surface temperature of the upper fusing roller exceeds 200° C), the signal from the 75-pin chip, IC201, changes from H to L to turn off the heater lamp forcibly.

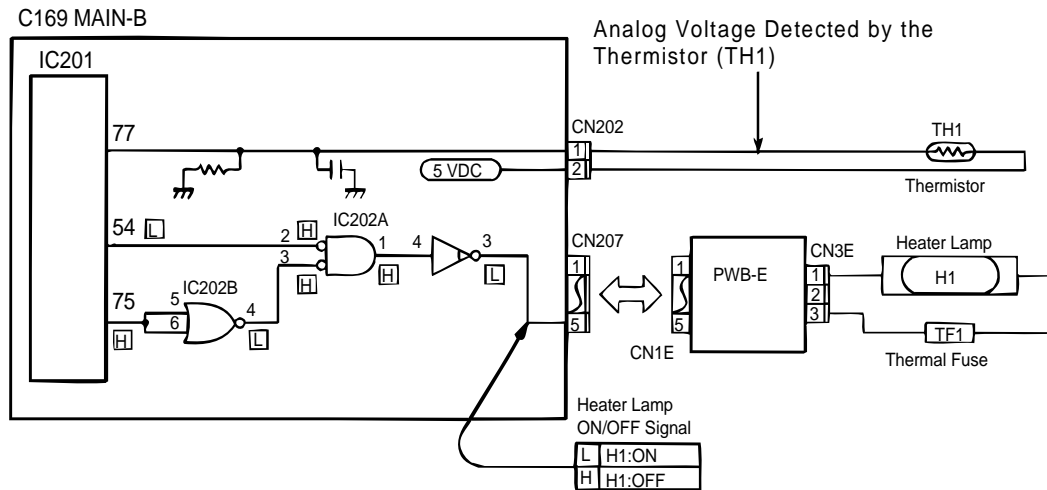

Figure 2-14. Fuser Control Circuit

The following figure shows the fuser temperature control procedure.

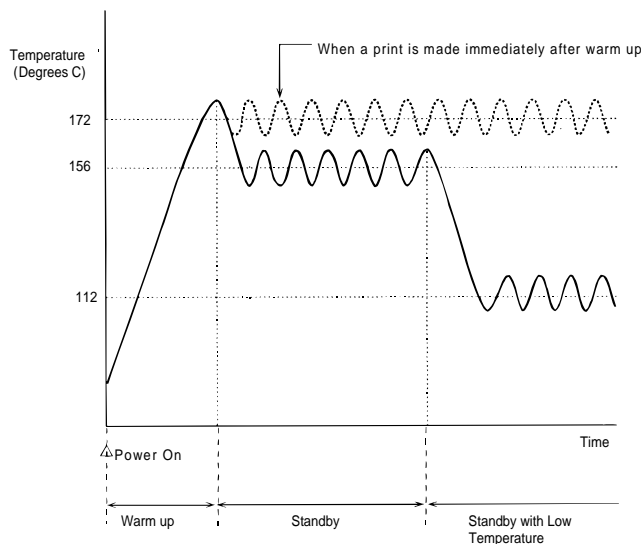

Figure 2-15. Temperature for Fuser Control Procedure

1. Warm up: After printer initialization, printer warm up starts, and the heater lamp turns on until the upper fusing roller's temperature reaches approximately 172° C.
2. Standby: In standby mode, the upper fusing roller's temperature is controlled to maintain 156° C. When this condition continues for 3 minutes, the printer goes into standby mode at low temperature.
3. Print cycle: When the printer receives the printing command from the controller, the upper fusing roller is controlled to maintain 172° C.
4. Standby at low temperature: The upper fusing roller is controlled to maintain 112° C.

If any of the following conditions are detected, the printer indicates a fuser error:

1. If the thermistor detects the temperature has not risen by 20° C for 50 msec. within 12 to 30 sec. after warm up. (This error applies only when the thermistor detects a temperature of 90° C or less.)
2. If the thermistor detects that the temperature has not reached 172° C within 60 sec. after warm up.
3. Except in pause mode (see the note below), if the thermistor detects that the temperature in the idle state has fallen to 80° C or lower for 50 msec., or the temperature during printing has fallen to 133° C or lower.
4. The thermistor detects that the temperature has exceeded 193° C for 50 msec. during temperature control.

Note: Pause Mode: In this mode, the control temperature is decreased to save power in the idle state, the heater lamp is turned OFF.

Thermo fuse TF1 cuts power if the temperature of the fusing section rises to an abnormally high level (over 200° C, 392° F).

2.1.2.4 Scanner Motor Control

Figure 2-16 is the scanner motor (M2) control circuit. The scanner motor is driven while it receives the POLYGON CTL signal. Motor rotation speed is 8622 rpm

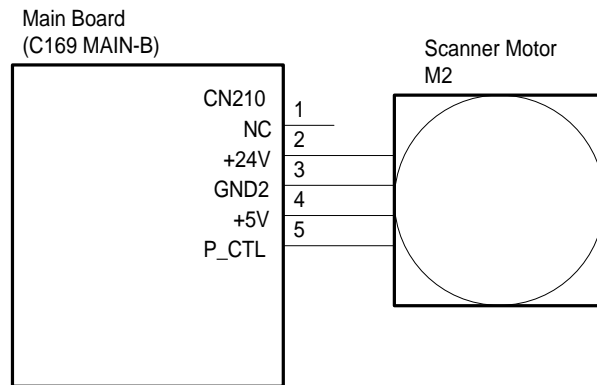

Figure 2-16. Scanner Motor Control Circuit

If the any of following conditions are detected, the printer indicates a scanner motor error:

1. The SSCAN signal has not been given once within 1 sec. after the scanner motor is energized.
2. The number of scanner motor rotations has not stabilized within ± 0.5 rpm by 4.2 sec. after the motor is energized.
3. The number of scanner motor rotations has exceeded $\pm 3\%$ for more than 0.5 sec. after the motor is energized, even if the rotation number stabilizes within ± 0.5 rpm.

2.1.2.5 Laser Diode Drive

Figure 2-17 shows the laser diode drive circuit. Laser diode emission is controlled by three signals (LDATA, LDAPC1, and LDAPC2) from the main board (C169 MAIN-B).

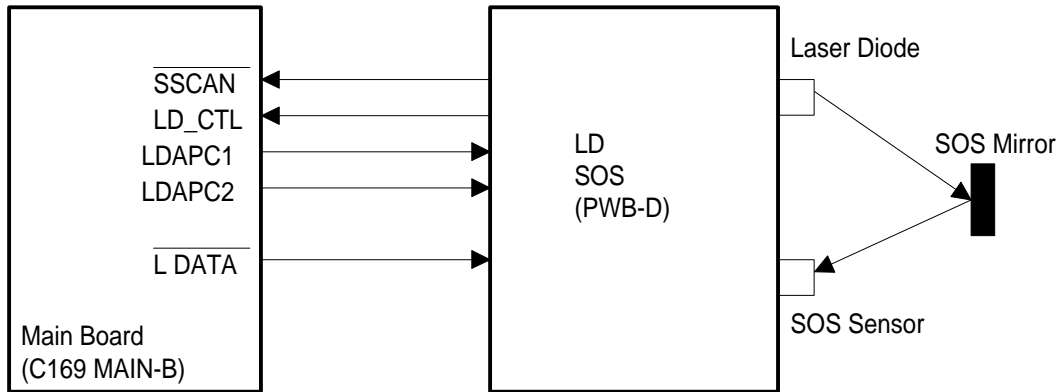

Figure 2-17. Laser Diode Drive Circuit

The $\overline{\text{L DATA}}$ signal is the laser on/off signal. When it is LOW, the laser emits, and when it is HIGH, the laser stops emitting. $\overline{\text{L DATA}}$ is the combination of the two signals in the figure below. If the $\overline{\text{VIDEO}}$ or the FORCED LASER DIODE ON signal is activated (LOW), the $\overline{\text{L DATA}}$ signal will be active. The $\overline{\text{VIDEO}}$ signal is an image signal sent from the video controller circuit. The FORCED LASER DIODE ON signal is a laser emission signal to apply the laser beam to the SOS sensor.

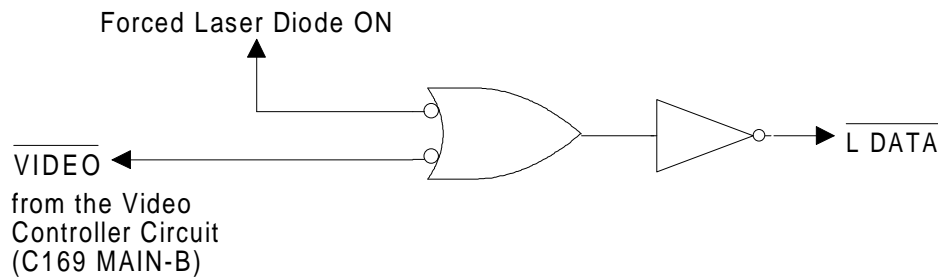

Figure 2-18. LDATA Generation Circuit

The laser diode is forcibly activated after scanner motor M2 turns on. At this time, laser emission power is adjusted. LDAPC1 and LDAPC2 are the laser emission power adjust signals; they are analog signals. LDAPC1 is a tuning, and LDAPC2 is a fine tuning.

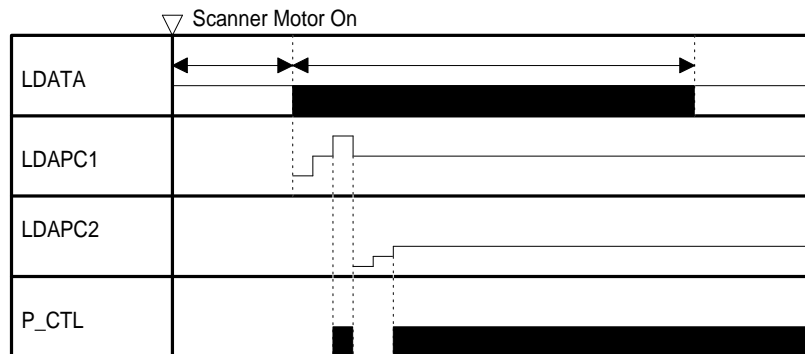

Figure 2-19. Laser Emission Power Adjustment Timing

If any of the following conditions are detected, the printer indicates a laser error:

The LDAPC1 signal or LDAPC2 signal has been out of the specified range while laser power is adjusted.

2.1.2.6 Bias Voltages and Laser Drive Timing

Figure 2-20 is a diagram of the drum charge bias voltage, image transfer bias voltage, and the developing bias voltage control circuit. These bias voltages are generated from the +24 VDC from the high-voltage supply board (PWB-F). If the printer detects a case-open condition, the interlock switch is set to off, which cuts the +24 VDC, which, in turn, cuts the bias voltages.

These bias voltages are controlled by the main board (C169 MAIN-B). The $\overline{HV-T}$ signal is the image transfer bias voltage control. While this signal is LOW, the image transfer electrode comb is charged to from +3 to +6K VDC by the high-voltage supply circuit. HV SEL1 and HV SEL2 are image transfer bias level control signals.

The HVB signal is the digital signal for developing bias voltage control. This signal controls the bias on/off. The BIAS MON signal controls the bias voltage level (-300 V to -375K VDC) using pulse data. The image density is controlled by the developing bias voltage level.

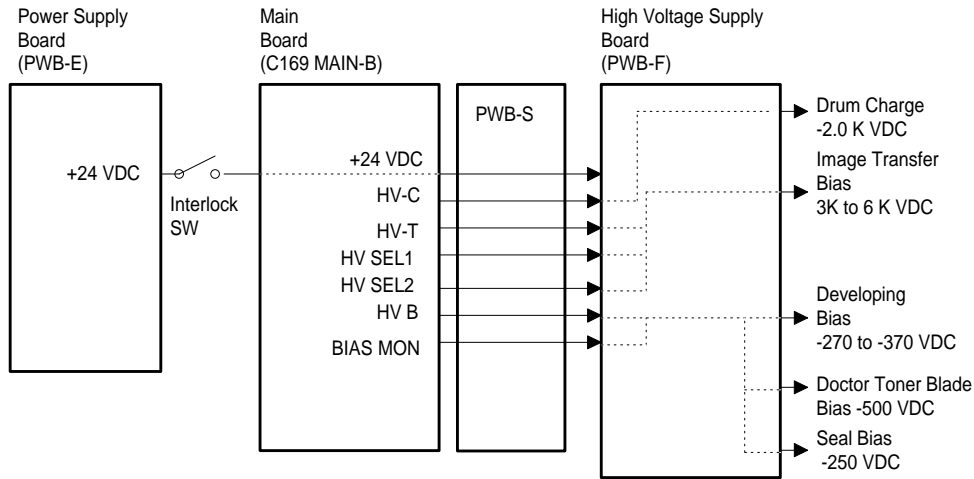

Figure 2-20. High-Voltage Supply Block Diagram

Figure 2-21 shows the print process.

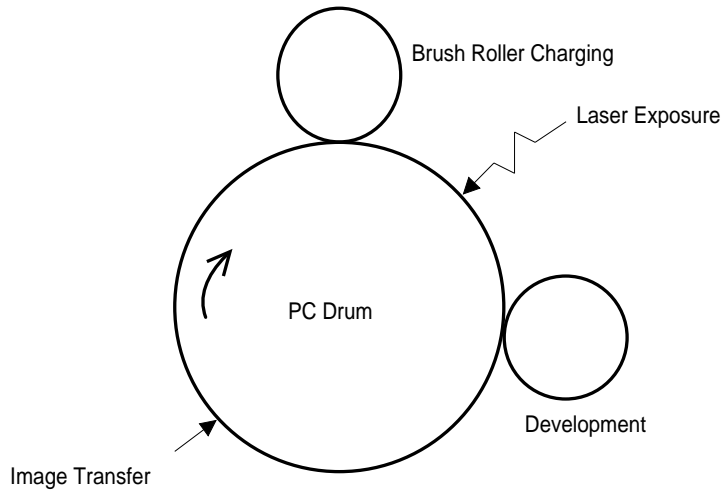

Figure 2-21. Print Process

Figure 2-22 shows the start print sequence. The printer's engine starts printing when it receives the PRINT signal from the video controller circuit.

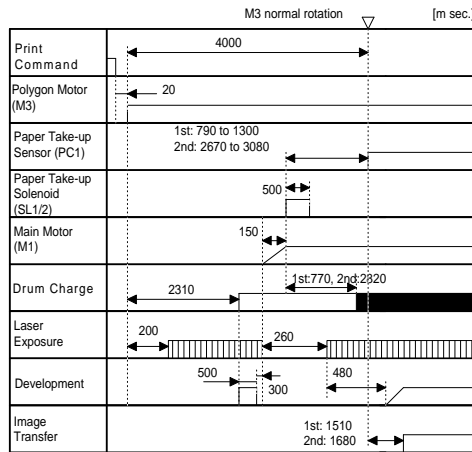

Figure 2-22. Print Sequence (Start)

Figure 2-23 is the end of the print sequence.

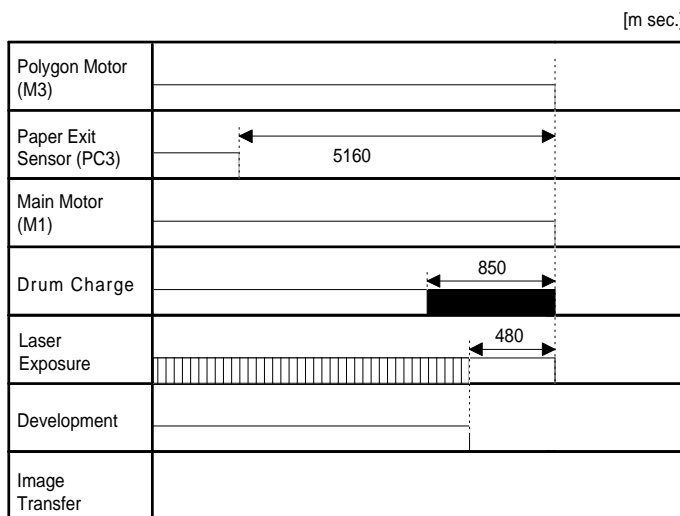

Figure 2-23. Print Sequence (End)

2.1.2.7 Fan Motor Control

The fan motor (M3) rotates at engine initialization, and stops after 2 sec. The fan motor also rotates during printing. When printing ends, the fan motor stops after 3 min. If the following condition is detected, the printer indicates a Fan motor error.

The voltage equivalent to the motor current of the fan motor remains 160 mV or lower for 2 sec.

2.1.2.8 Power Supply Circuit Function and Safety Protection

The printer's power supply board (PWB-E) supplies the +5 VDC and +24 VDC. The +24 VDC is used as the bias voltage supply, main motor (M1) drive, scanner motor (M2) drive, fan motor (M3) drive, and solenoid drive. For safety protection, the +24 VDC line is cut when the interlock switch (case open switch) is off.

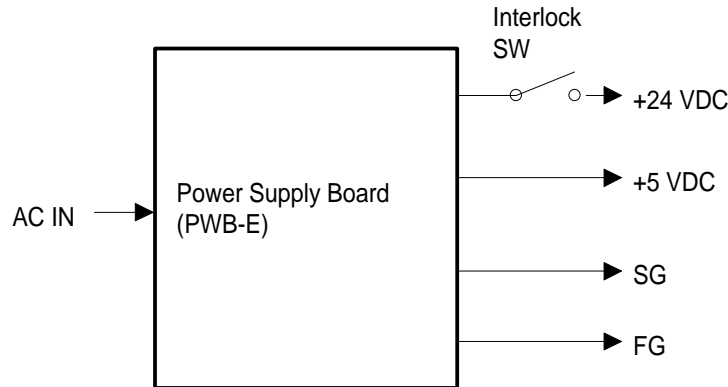

Figure 2-24. Power Supply Circuit Block Diagram

2.2 VIDEO CONTROLLER OPERATION

The video controller section generates the video signals for received data. The video controller section is the C169 MAIN-B Board.

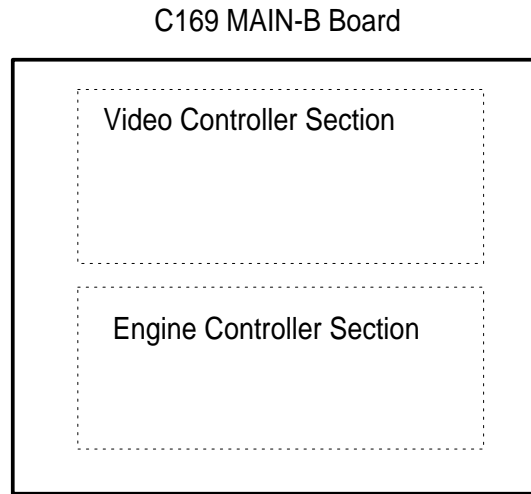

Figure 2-25. Video Controller Section

2.2.1 C169 MAIN-B Board Operation

Figure 2-26 shows a block diagram of video controller section of the C169 MAIN-B Board. The C169 MAIN-B Board contains the video controller, which consists of a MB86933H (SPARKlite, 22.5 MHz, 32-bit bus) RISC CPU; the standard cells developed for this printer; DRAMs; ROM; and an EEPROM.

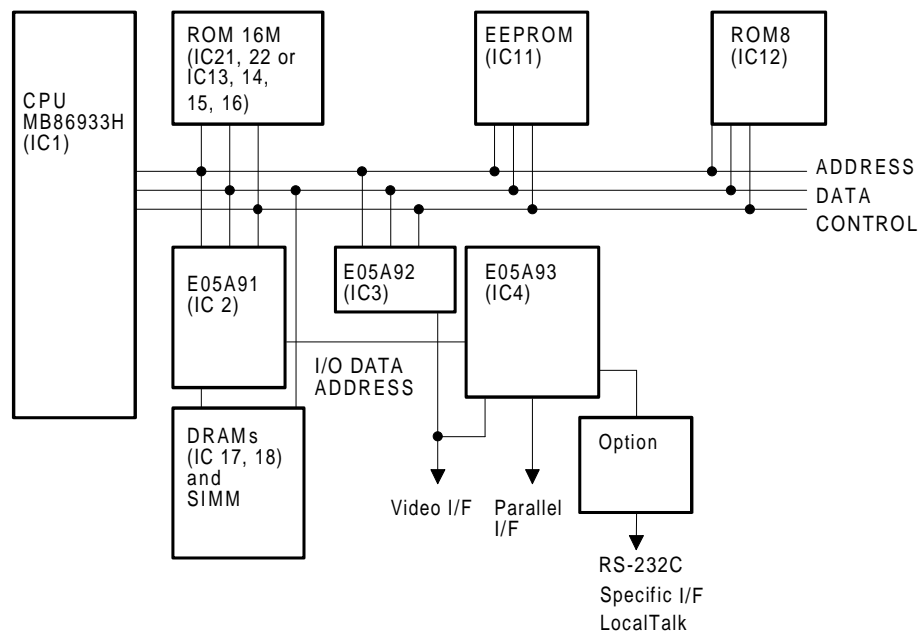

Figure 2-26. C169 MAIN-B Board Block Diagram

Table 2-1 lists the functions of the main elements of the video controller section in C169 MAIN-B Board.

Table 2-1. Functions of C169 MAIN-B Board Main Elements

Element	Location	Function
MB86933H RISC CPU	IC1	The CPU, which operates at 22.5 MHz, manages the video controller operation.
E05A91 ASIC	IC2	This ASIC contains the following functions: <ul style="list-style-type: none"> •Address decoding •DRAM management (refresh control, RAS/CAS control)
E05A92 ASIC	IC3	This ASIC contains the following functions: <ul style="list-style-type: none"> •Video signal processing •Toner save function •BiRITech •EMGTech
E05A93 ASIC	IC4	This ASIC contains the following functions: <ul style="list-style-type: none"> •Video interface •Bi-parallel interface •LocalTalk module control •Type-B EX interface box control
Two 8M ROMs or four 4M ROMs	IC21,22 or IC13,14,15,16	These ROMs are code and font ROMs.
8M ROM	IC12	This ROM is a local language (font) ROM option (except in the U.S. model).
EEPROM	IC11	This EEPROM stores the following: <ul style="list-style-type: none"> •Model type •Printed page counter value •Jam counter value •Printer setting
DRAM	IC17,18	These DRAMs are used as the working area of the CPU: input buffer, image buffer, etc.

Print data and commands transmitted from the host computer via the parallel or optional interfaces are read using the CPU interrupt process and stored in the DRAM input buffer. Data and commands in the input buffer are processed by the CPU, which then stores the printing bitmap data (image data) in the V (video) -RAM (image buffer) area of the DRAM. The size of the V-RAM depends on the available DRAM size. A "PRINT OVERRUN" occurs when the V-RAM is so small that the CPU cannot process data faster than it is transmitted to the engine controller board. If such an error occurs, the user can increase the V-RAM using the printer setting "IMAGE OPTIMUM."

The E05A91 transmits image data stored in the V-RAM to the E05A92. The E05A92 changes the image data format from 32-bit parallel data to serial data, and stores it in the internal temporary buffer. The temporary buffer has a capacity equivalent to several lines. This is controlled by the E05A92, which synchronizes and transmits the temporary buffer's data to the engine controller board. The E05A92 then manipulates the printer data based on the BiRITech, EMGTech, and toner saver settings.

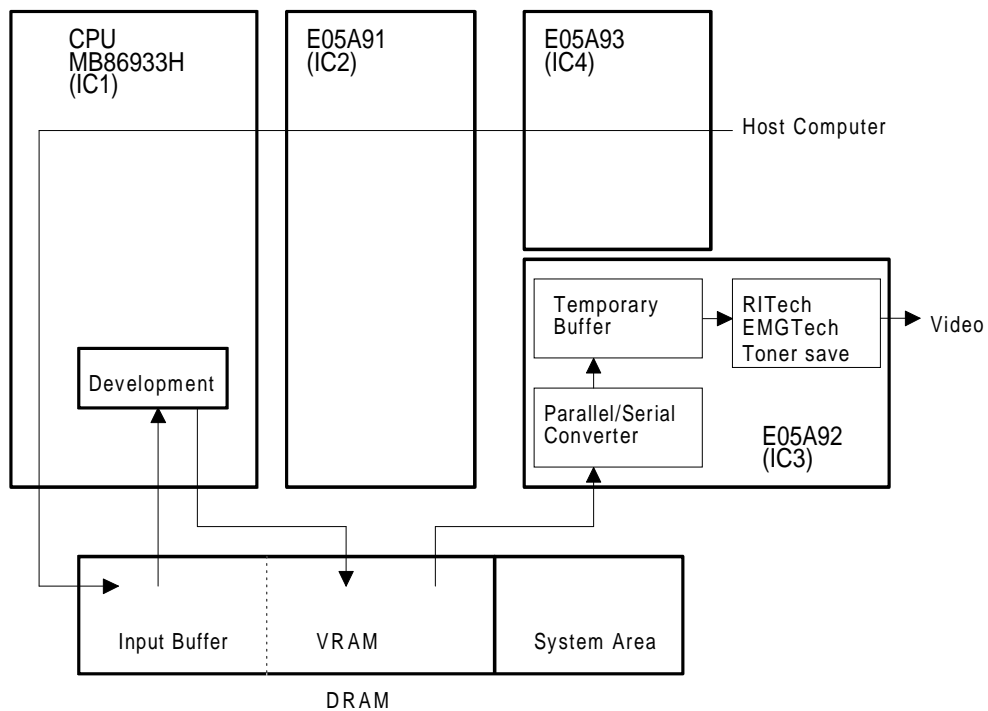

Figure 2-27. Data Flow Diagram

2.2.1.1 Reset Circuit

The entire system (CPU and external devices) can be initialized if the RESET signal (CPU pin 113) are active simultaneously. This circuit uses an M51938 IC to monitor the supply voltage if a voltage level less than 4.25 V is detected. The reset time is approximately 128 ms.

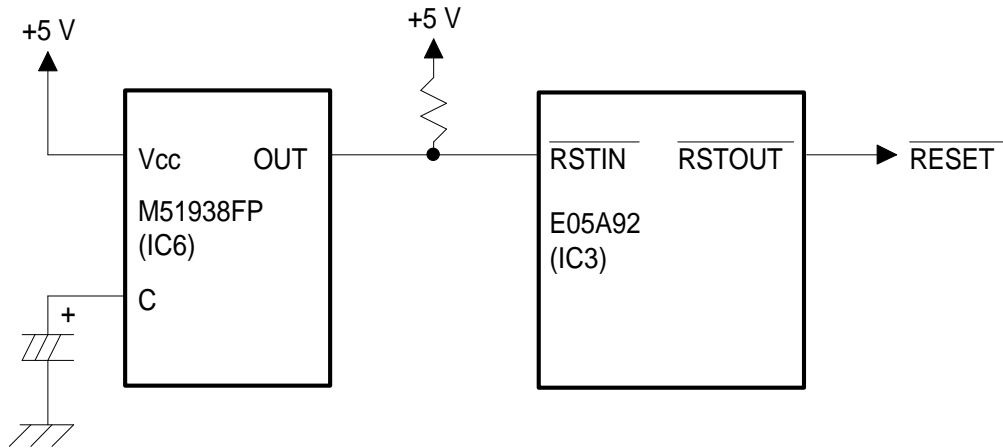

Figure 2-28. Reset Circuit

2.2.1.2 Bus Control Circuit

The MB86930 CPU outputs the R/W (read/write) signal, AS (address strobe) signal, and the BE0, BE1, BE2, and BE3 signals (byte enables) to the ASIC E05A91. The ASIC E05A91 uses these signals to generate the RD (read strobe) signal, WR (write strobe) signal, and READY signal.

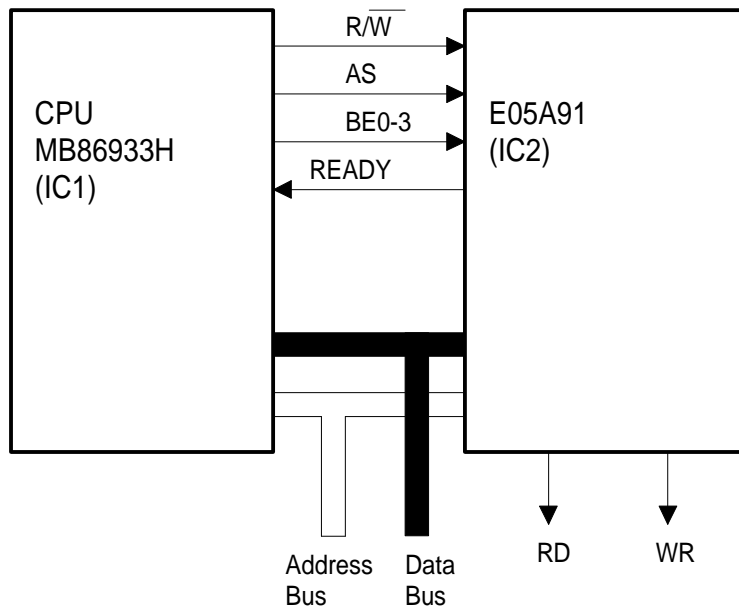

Figure 2-29. Bus Control Circuit

2.2.1.3 Interrupt Control

The ASIC E05A93 determines the priority level of the interrupt and outputs it to terminals IRL0 - IRL3. Then an interrupt is sent to the CPU. When the IRL0-3 value is 1111b, the CPU process is a non-maskable interrupt process. When the IRL0-3 value is 0000b, the CPU process is a standard process. When the IRL0-3 is any other value, the CPU process is a maskable interrupt process.

2.2.1.4 DRAM Management

The video controller uses DRAMs for the system RAM and for the V-RAM. In this printer, a standard two 512K × 16 DRAMs are mounted in locations IC17 and IC18, providing a total of 1MB. CN2 SIMM sockets are provided for optional SIMM memory modules. These SIMM sockets can use 1, 2, 4, 8, 16, and 32 MB SIMMs (32-bit bus).

The DRAMs (including optional SIMMs) are managed by the ASIC E05A91. E05A91 outputs MA0-10 (memory address), RAS/CAS, and WE signals.

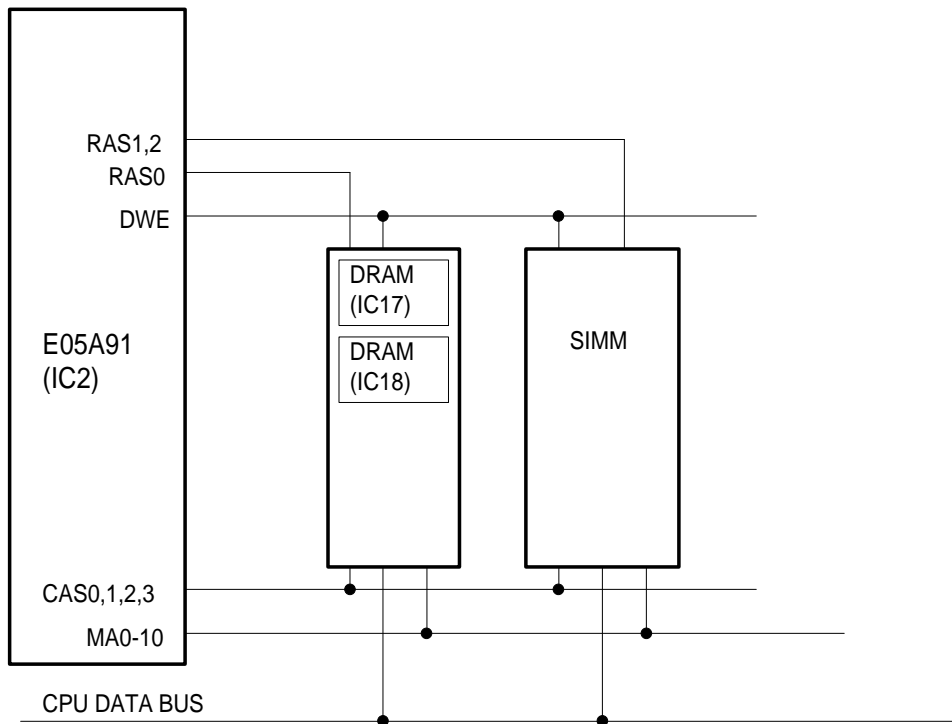

Figure 2-30. DRAM Management

2.2.1.5 Parallel Interface Circuit

Figure 2-31 shows a circuit block diagram of the parallel interface. Data sent from the host computer is latched within the E05A93 by the $\overline{\text{STROBE}}$ signal. The E05A93 outputs a BUSY signal automatically to stop the host computer from sending additional data. The CPU resets the BUSY signal after reading the data from the E05A93, so that the printer is ready to receive more data from the host computer.

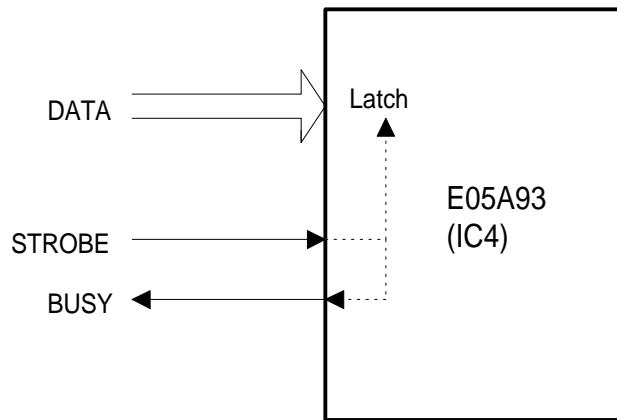

Figure 2-31. Parallel Interface Circuit

2.2.1.6 Video Interface

The ASIC E05A92 maps the SRAM into a memory space different from the system memory. The CPU transmits data from the V-RAM (in the system RAM) to the SRAM using the ASIC E05A92. The ASIC cell converts the image data in the SRAM from parallel to serial, synchronizes it, and then transmits it to the engine controller board. In other words, the SRAM is a temporary buffer used to transmit the image data to the engine controller board. This serial image data is called the VIDEO signal of video interface.

The signal line of the internal video interface circuit (the C125 MAIN board and engine controller board) can be broadly divided into four groups. The first group (PRINT, CPRDY, EPRDY, and PRDY) gives the status of either the video controller or engine controller and indicates whether they are ready to communicate with each other or ready to start the printing operation. The second group (VSYNC, HSYNC) is the synchronizing signal for the printing operation. The third group (VIDEO) is the serial video data signal. The fourth group (CMD, SRCLK, CTBSY, and ETBSY) is used to transfer the commands (from the video controller) or the status (from the engine controller) for printer mechanism control. Except for VIDEO, PRINT, VSINC, and HSYNC, all signals are controlled by ASIC E05A93.

This printer has BiRITech and EMGTech functions standard. These functions modify the VIDEO signal with the ASIC E05A92.

Chapter 3 Disassembly and Assembly

Table of Contents

3.1 GENERAL INFORMATION	3-1
3.1.1 Precautions for Disassembly/Assembly	3-1
3.1.2 Tools	3-1
3.1.3 Small Parts	3-2
3.1.4 Service Checks after Repair.	3-3
3.2 DISASSEMBLY AND ASSEMBLY	3-4
3.2.1 Housing Removal	3-4
3.2.1.1 Case Removal	3-4
3.2.2 Removal of the Controller Section	3-5
3.2.2.1 Main Board (C169 MAIN-B Board) Removal	3-5
3.2.3 Disassembling the Engine	3-6
3.2.3.1 Optical Unit Removal	3-6
3.2.3.2 Image Transfer Unit Removal	3-7
3.2.3.3 Upper Unit Removal	3-9
3.2.3.4 High-Voltage Supply Board (PWB-F) Removal	3-10
3.2.3.5 Power Supply Unit (PWB-E) Removal	3-11
3.2.3.6 Fusing Unit Removal	3-12
3.2.3.7 Fusing Unit Disassembly	3-15
3.2.3.8 Main Motor Removal	3-20
3.2.3.9 Paper Take-Up Sensor and Paper Take-Up Solenoid Removal	3-21
3.2.3.10 Paper Take-Up Roller Removal	3-22

List of Figures

Figure 3-1. Removing the Housing	3-4
Figure 3-2. Removing the Shield Case	3-5
Figure 3-3. Removing the C169 MAIN-B Board	3-5
Figure 3-4. Removing the Optical Unit	3-6
Figure 3-5. Removing the Image Transfer Unit -1.	3-7
Figure 3-6. Removing the Image Transfer Unit -2.	3-7
Figure 3-7. Moving the Image Transfer Unit	3-8
Figure 3-8. Reinstalling the Electrode Comb	3-8
Figure 3-9. Removing the Harness Cover.	3-9
Figure 3-10. Removing the Upper Unit	3-9
Figure 3-11. Removing the PWB-F Cover.	3-10
Figure 3-12. Removing the PWB-F	3-10
Figure 3-13. Removing the PWB-E Cover	3-11
Figure 3-14. Removing the PWB-E	3-11
Figure 3-15. Gear and Spring Position	3-12
Figure 3-16. Removing the Fusing Guide Plate	3-12
Figure 3-17. Removing the Harness Cover.	3-13
Figure 3-18. Removing the Fusing Entrance Guide	3-13
Figure 3-19. Removing the Fusing Unit.	3-14
Figure 3-20. Roller Position.	3-14
Figure 3-21. Removing the Heater Lamp	3-15
Figure 3-22. Removing the Thermistor	3-16
Figure 3-23. Wiring	3-16

Figure 3-24. Removing the Paper Separator	3-17
Figure 3-25. Paper Exit Sensor	3-17
Figure 3-26. Removing the G-Rings.	3-18
Figure 3-27. Removing the Upper Fusing Roller	3-18
Figure 3-28. Removing the Lower Fusing Roller	3-19
Figure 3-29. Removing the Thermal Fuse	3-19
Figure 3-30. Removing the Motor Bracket	3-20
Figure 3-31. Removing the Main Motor	3-20
Figure 3-32. Removing the Ground Plate	3-21
Figure 3-33. Removing the Paper Guide ASSY.	3-21
Figure 3-34. Removing the Gears	3-22
Figure 3-35. Removing the Paper Take-Up Roller.	3-22

List of Tables

Table 3-1. Tools	3-1
Table 3-2. Screw Types and Abbreviations	3-2
Table 3-3. Checks after Repair	3-3

3.1 GENERAL INFORMATION

This chapter describes disassembly/assembly procedures to be used for replacing the main assemblies of the EPL-5500.

3.1.1 Precautions for Disassembly/Assembly

Follow the precautions below when disassembling/assembling the printer.

WARNING

- Disconnect the power cord before disassembling/assembling the printer.*
- Be sure to handle the fusing unit carefully, because the unit remains hot for a while after the printer stops printing.*
- If it is necessary to plug in the power cord and operate the printer after disassembling it, please be careful of the following:*
 - 1. Keep your hands and clothing well away from operating or rotating parts (such as rollers, fan motors, etc.).*
 - 2. Never touch electric terminals or high-voltage components (such as the charger and the high voltage unit).*

CAUTION

- Do not disassemble the photoconductor unit and toner cartridge.*
- If the photoconductor unit is removed from the printer, do not place it in direct sunlight.*
- Do not disassemble the optical unit.*
- Never turn power on if the optical unit is not installed.*
- To prevent damage to ICs from static electricity, do not touch the ICs on the circuit board or the terminals of peripheral electrical components with your hands.*
- Use only the recommended tools to ensure safe and efficient maintenance work. Inappropriate tools may damage the machine.*
- Never open the upper unit until the main motor stops completely. Otherwise, the gears may be damaged.*
- When transporting the printer, remove the photoconductor unit and toner cartridge from the printer.*
- When transporting the printer a long distance, pack up the printer using the original packing material.*

3.1.2 Tools

Use the tools listed in Table 3-1 for disassembling/assembling the printer and for troubleshooting.

Table 3-1. Tools

Name	Commercially Available?	Part No.
Philips screwdriver no. 2	Yes	B743800200
Regular screwdriver	Yes	B743000100
Tweezers	Yes	B641000100
Soldering iron	Yes	B740200100
Round-nose pliers	Yes	B740400100

3.1.3 Small Parts

In the following sections, abbreviations are used for small parts, such as screws and washers. Tables 3-2 and 3-3 list these abbreviations.

Table 3-2. Screw Types and Abbreviations

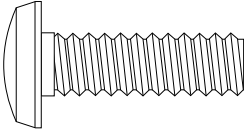
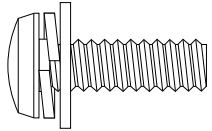
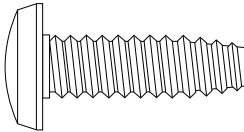
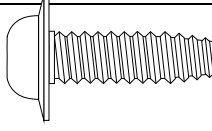
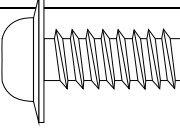
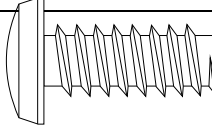
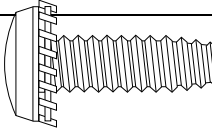
No.	Type	Standard		Appearance
		Size (mm)	Length (mm)	
#1	CB	4	8	
#2	CB(S)(P1)	3	6/8	
#3	CBS	3	6/8/14	
#4	CCS	3	6/8/10/12	
#5	CCB	3	8	
#6	CBB	3	8	
#7	CBS(O)	3	8	
	Pin			
	E-Ring			

3.1.4 Service Checks after Repair

Check the repaired unit using the following list on completion of servicing.

Table 3-3. Checks after Repair

Item	Location	Checkpoint	Check
Operation	Control panel	Do all LEDs and button function normally?	
	Heater lamp	Does the heater lamp turn on normally?	
	Test print (status sheet)	Is the test print performed normally?	
	Data print	Does data print in all modes?	
Adjustment	Print position	Is the gap between the top edge of the paper and the horizontal line in the status sheet print exactly 29.6 mm (1.17 inch).	
ROM version		Is it the latest version?	
Cleaning		Is toner and dust removed from the paper path? Is the paper take-up roller cleaned? Is the roller in the fusing unit cleaned? Is the outer surface of the printer clean?	
Packing		Is the consumable removed from the printer? Is the unit packed securely? Are accessories packed also?	

3.2 DISASSEMBLY AND ASSEMBLY

This section describes and illustrates the procedures for removing and disassembling the components of the EPL-5500. Cleaning is described in Chapter 6. The assembly procedures are not described, except for special notes where necessary, because assembly can be accomplished by performing disassembly in reverse.

3.2.1 Housing Removal

This section describes how to remove the cases and the rear frame.

3.2.1.1 Case Removal

1. Push the upper unit lock release button and open the upper unit.
2. Remove each cover in the following turn.

ASSEMBLY POINTS

When reinstalling each cover, securely insert the protrusions of the cover into the cutouts of the printer frame.

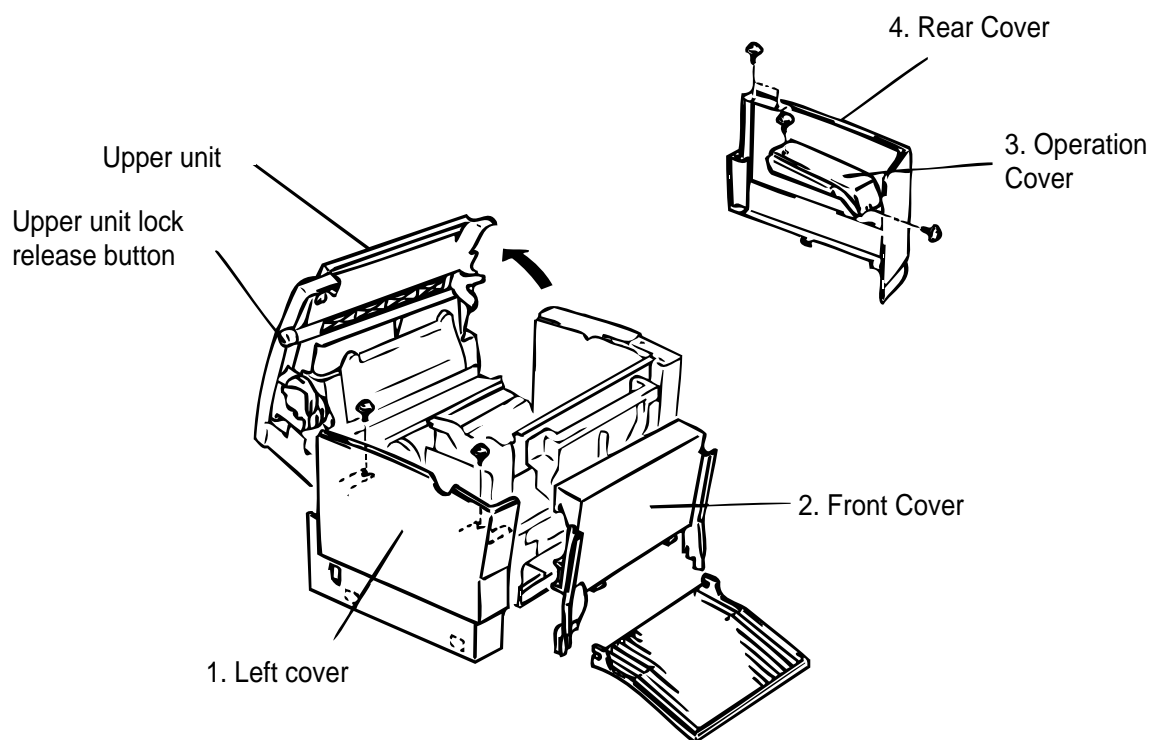

Figure 3-1. Removing the Housing

3.2.2 Removal of the Controller Section

The control section is comprised of the controller board (the C169 MAIN-B Board).

3.2.1.1 Main Board (C169 MAIN-B Board) Removal

CAUTION

Before you remove the video controller board, make sure that you remove any optional LocalTalk/ serial board or Type-B EX box.

1. Turn the printer so that its right side faces you.
2. Remove the right cover.
3. Remove 2 screws (#3), and then remove the shield case.

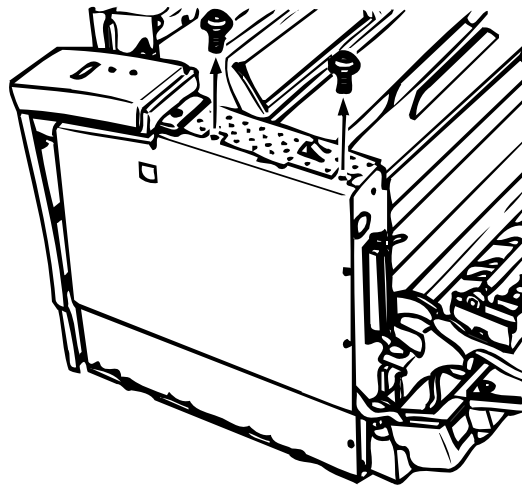

Figure 3-2. Removing the Shield Case

4. Disconnect all connectors on the C169 MAIN-B Board.
5. Remove the 5 screws (#4) for the C169 MAIN-B Board.
6. Remove the C169 MAIN-B Board.

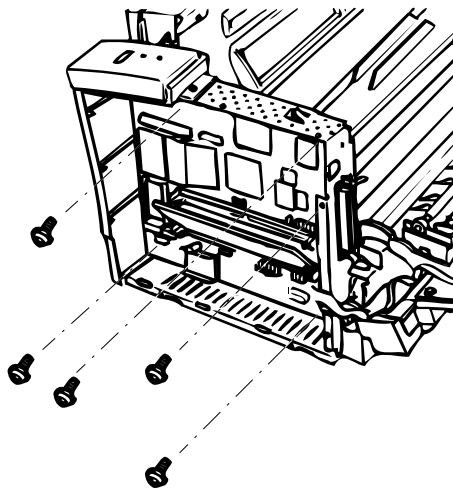

Figure 3-3. Removing the C169 MAIN-B Board

3.2.3 Disassembling the Engine

This section describes disassembling the engine, including the high voltage unit (PWB-F) and power supply board (PWB-E).

3.2.3.1 Optical Unit Removal

CAUTION

- Do not touch the optical unit except at the time of replacement.
- Do not open the unit under any conditions.
- Do not remove the circuit board from the optical unit under any conditions.

1. Open the top cover.
2. Remove the right cover, left cover, and front cover. (Refer to Section 3.2.1.1.)
3. Remove the cover shield plate.
4. Disconnect connector CN205 and CN210 from the C169 MAIN Board.
4. Remove the 6 screws (#4) from the optical unit.
5. Remove the optical unit.

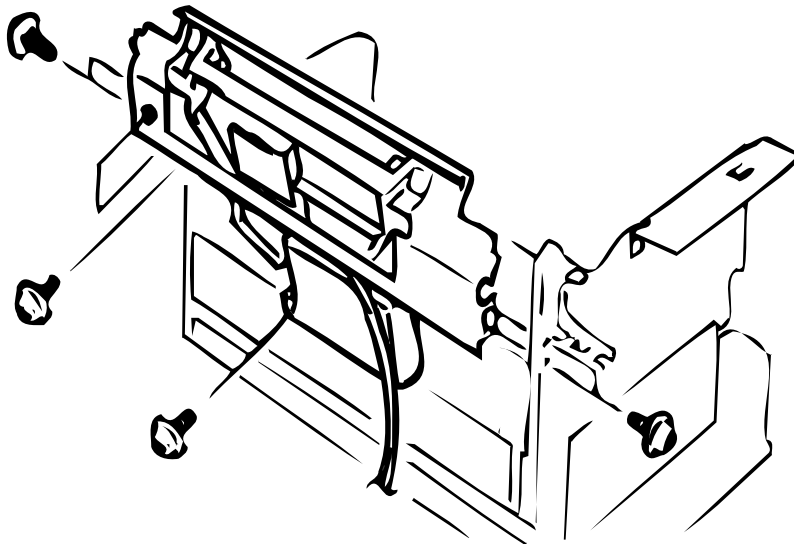

Figure 3-4. Removing the Optical Unit

3.2.3.2 Image Transfer Unit Removal

1. Open the top cover.
2. Remove the harness cover A. (Refer to Section 3.2.3.3.)
3. Remove the 2 screws (#5) and holders at both ends of the image transfer unit.

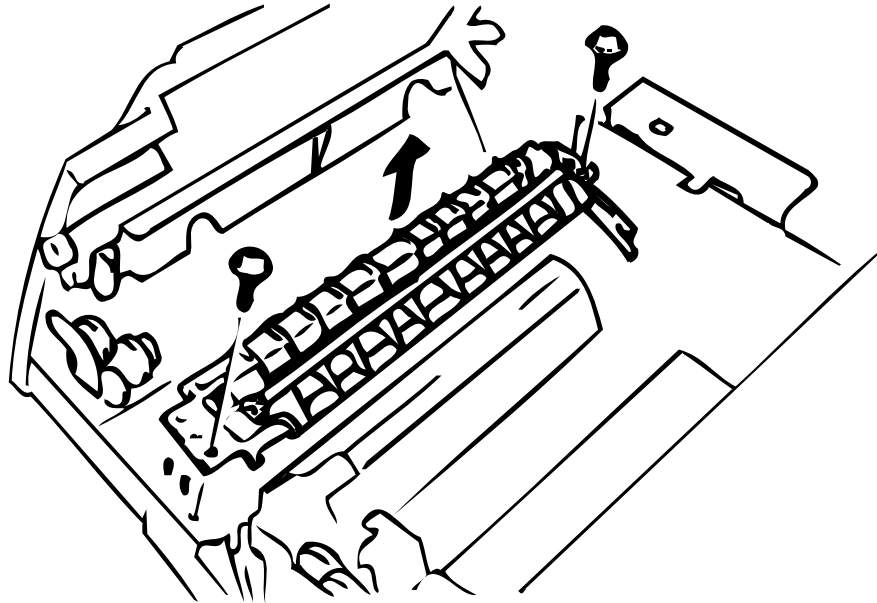

Figure 3-5. Removing the Image Transfer Unit - 1

4. Disconnect the 2 connectors and remove the unit.

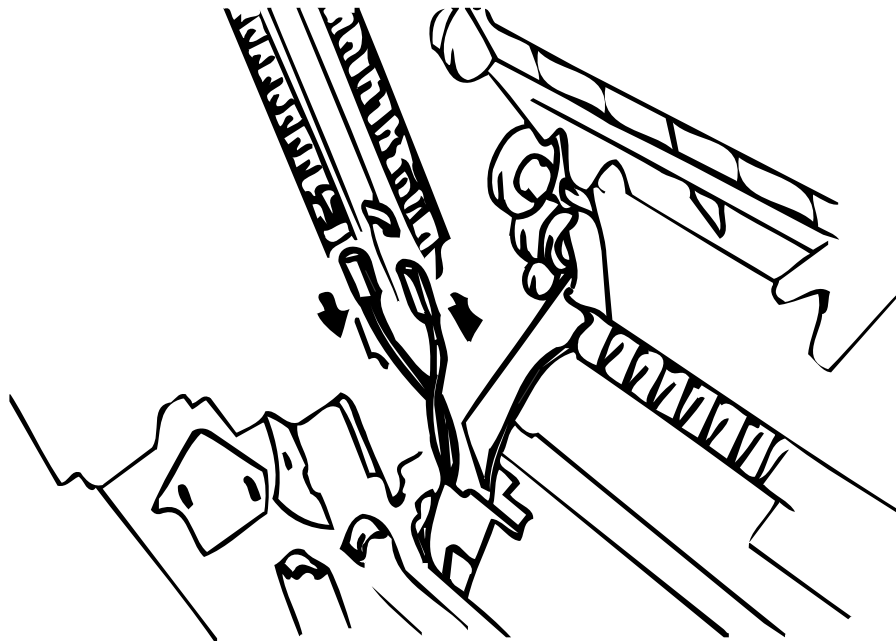

Figure 3-6. Removing the Image Transfer Unit - 2

ASSEMBLY POINTS

After reinstalling the image transfer unit, check that the unit smoothly moves up and down.

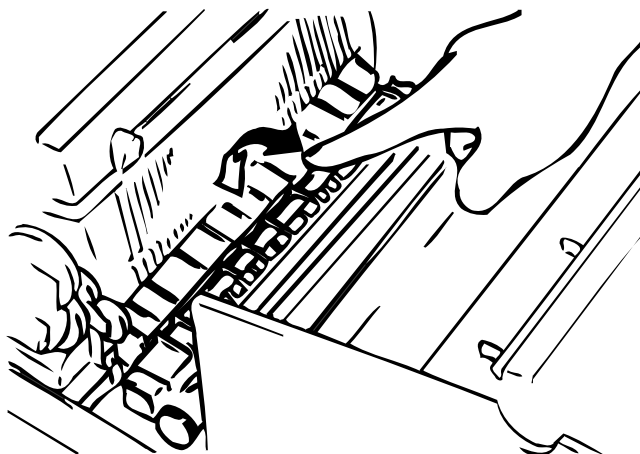

Figure 3-7. Moving the Image Transfer Unit

- 5. Remove the remove the electrode comb.

ASSEMBLY POINTS

When reinstalling the electrode comb, be careful of the direction of installation. Install the electrode comb so that the terminal of the comb faces the image transfer roller drive gear.

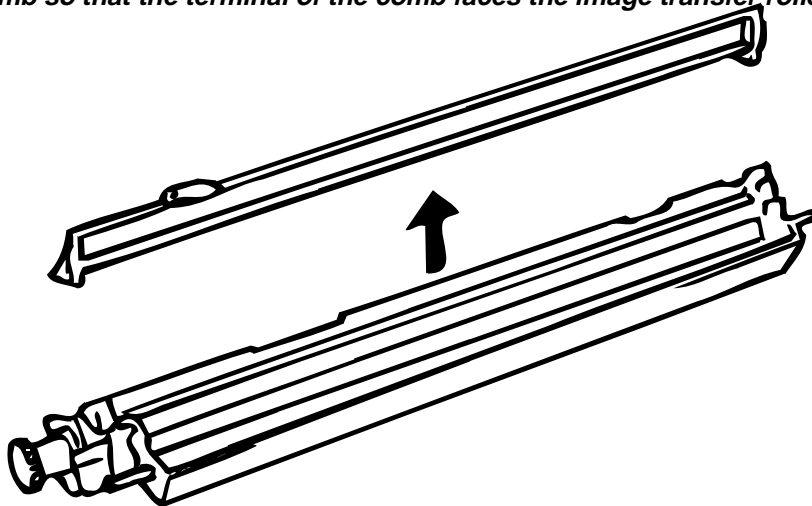

Figure 3-8. Reinstalling the Electrode Comb

3.2.3.3 Upper Unit Removal

1. Open the upper unit.
2. Remove the right cover and left cover. (Refer to Section 3.2.1.1.)
3. Disconnect connectors CN202, CN208, and CN211 from the C169 MAIN-B.
4. Remove harness covers A and B, and pull out the CN1 of the PWB-E board.
5. Remove the image transfer unit. (Refer to Section 3.2.3.2.)

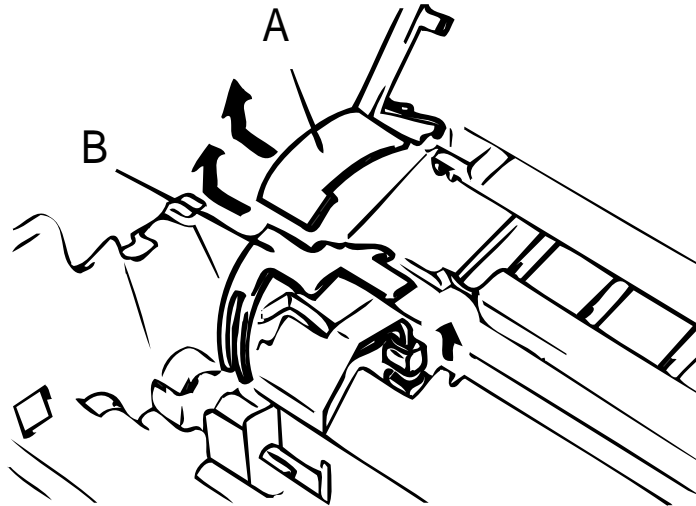

Figure 3-9. Removing the Harness Cover

6. Slide and remove the unit as in the illustration.

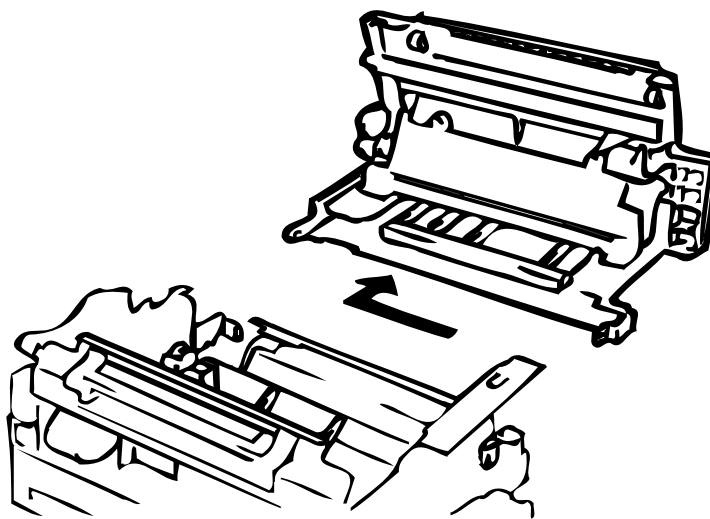

Figure 3-10. Removing the Upper Unit

3.2.3.4 High-Voltage Supply Board (PWB-F) Removal

1. Open the top cover.
2. Remove 1 screw (#5) from the PWB-F cover.
3. Remove the PWB-F cover.

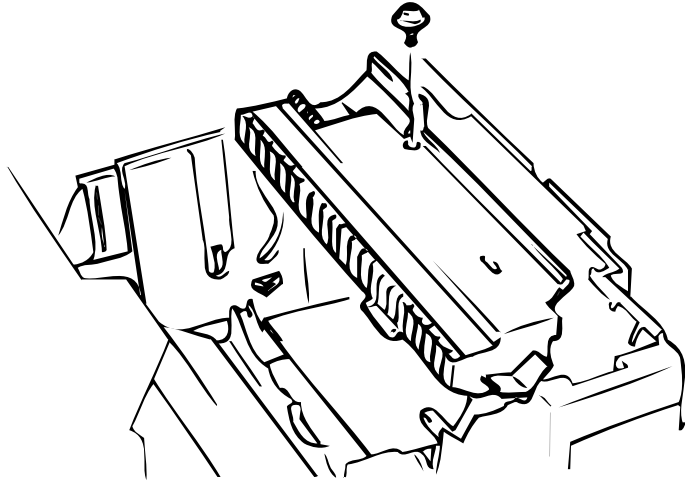

Figure 3-11. Removing the PWB-F Cover

4. Remove the 4 screws (#5) from the PWB-F board.
5. Disconnect 2 connectors.
6. Remove the PWB-F board.

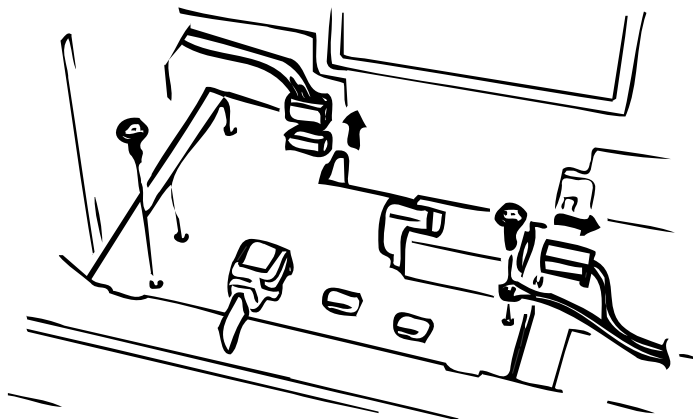

Figure 3-12. Removing the PWB-F

3.2.3.5 Power Supply Unit (PWB-E) Removal

1. Remove the upper unit. (Refer to Section 3.2.3.3.)
2. Remove 6 screws (#4:2, #7:2), and remove the PWB-E cover.

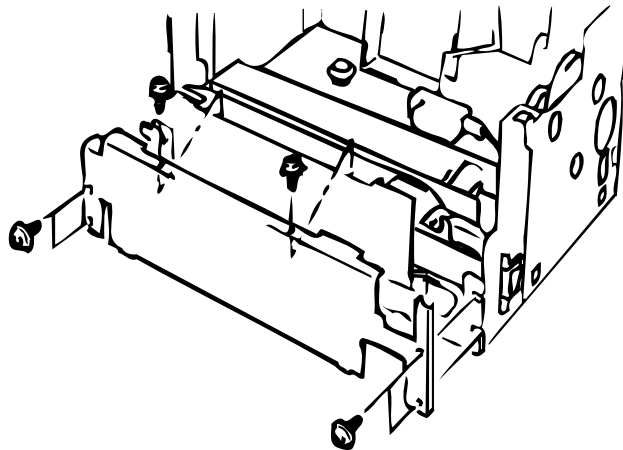

Figure 3-13. Remove the PWB-E Cover

3. Disconnect connector CN207 from the C169 MAIN-B Board.
4. Remove 4 screws (#4) and 2 screws (#6), and remove the PWB-E.

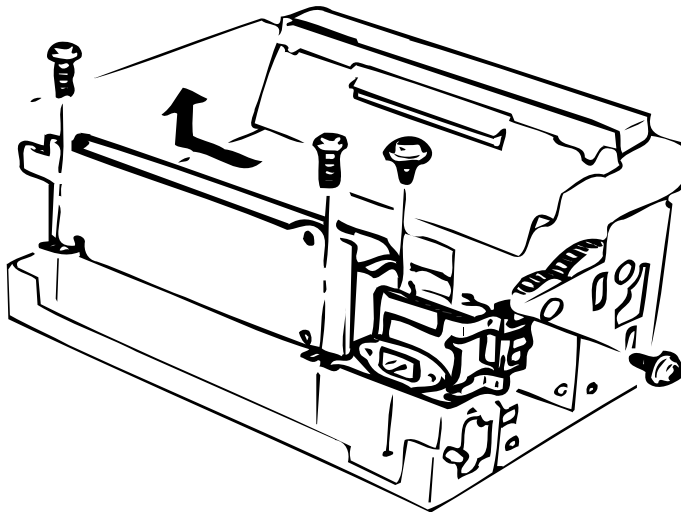

Figure 3-14. Removing the PWB-E

3.2.3.6 Fusing Unit Removal

1. Open the top cover. (Refer to Section 3.2.3.3.)
2. Remove the image transfer unit. (Refer to Section 3.2.3.2.)
3. Remove 1 screw (#5), and remove the drive tension section of the fusing unit.
4. Remove the transport gear.
5. Release the hook of the spring and remove the drive gear section of the fusing unit.

ASSEMBLY POINTS

When rehooking the spring, be sure to hook it at the correct position.

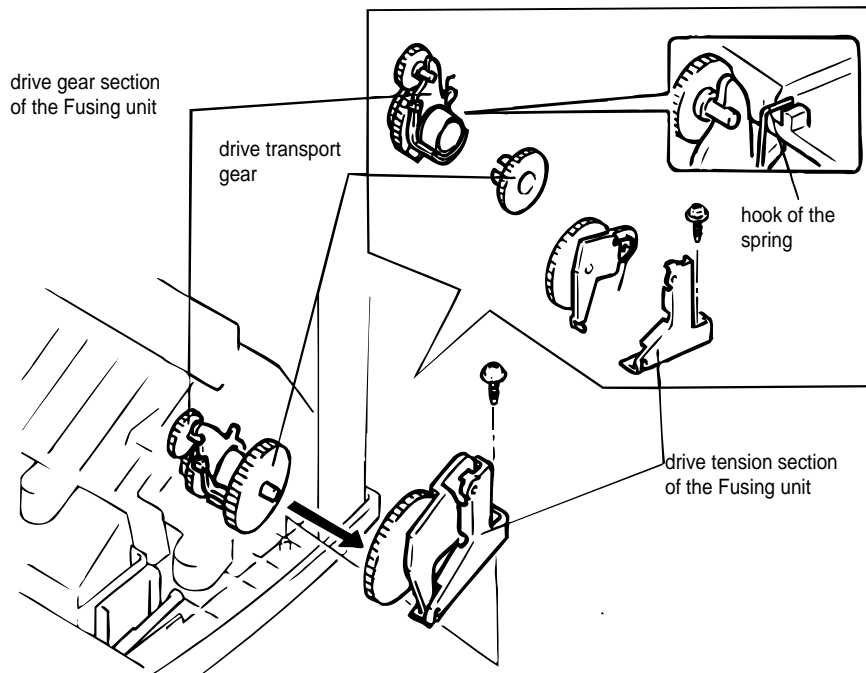

Figure 3-15. Gear and Spring Position

6. Remove 4 screws (#5), and remove fusing guide plate.

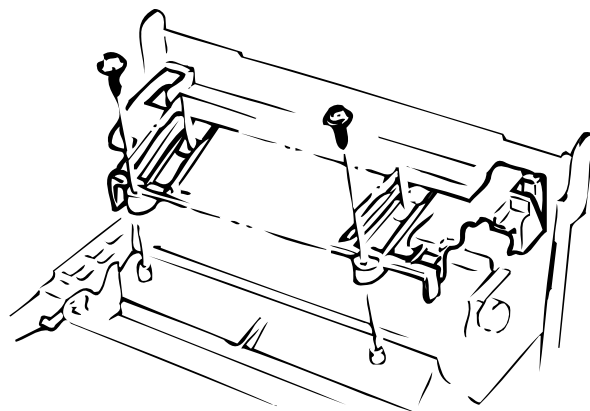

Figure 3-16. Removing the Fusing Guide Plate

7. Remove the harness cover.

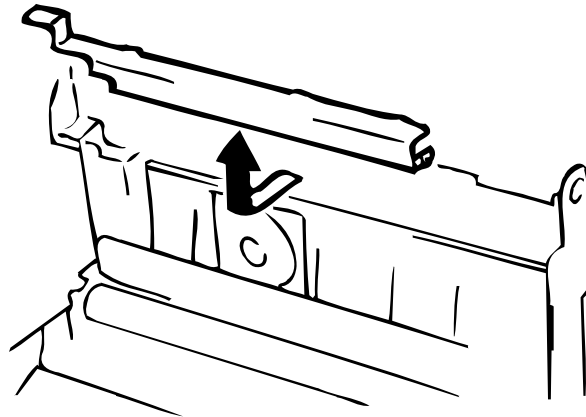

Figure 3-17. Removing the Harness Cover

8. Remove the fusing entrance guide.

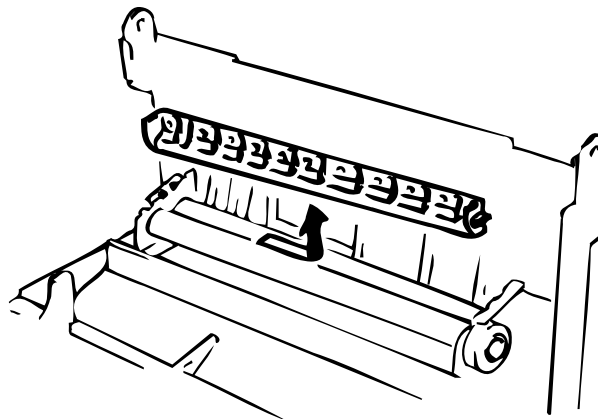

Figure 3-18. Removing the Fusing Entrance Guide

10. Remove 4 screws (#5), and remove the fusing unit.

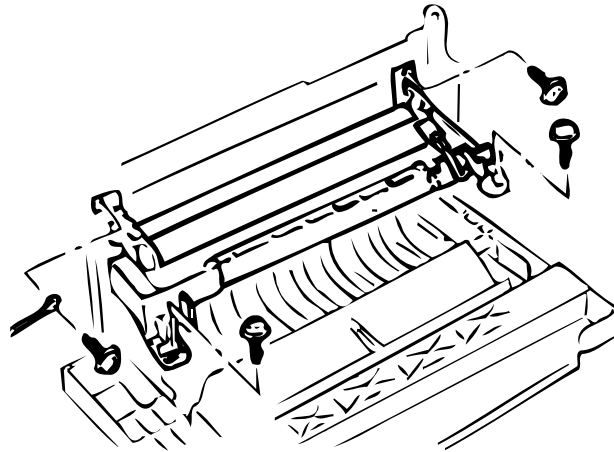

Figure 3-19. Removing the Fusing Unit

ASSEMBLY POINTS

After reinstalling the fusing unit, check the direction of the bushings on the paper exit roller and the connection condition between the roller and the ground plate.

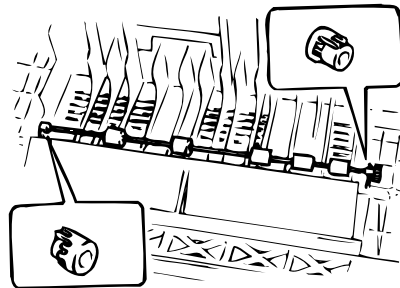

Figure 3-20. Roller Position

3.2.3.7 Fusing Unit Disassembly

This section describes how to remove the paper exit sensor, heater lamp, lower fusing roller, and upper fusing roller.

Heater Lamp

CAUTION

Do not touch the glass surface of the lamp with your bare hands.

1. Remove the fusing guide plate. (Refer to Section 3.2.3.6.)
2. Pull the heater lamp out of the lamp holder from the front side.

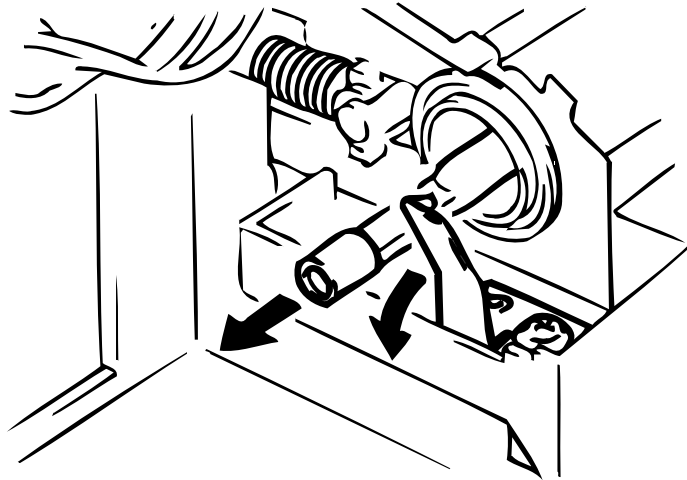

Figure 3-21. Removing the Heater Lamp

ASSEMBLY POINTS

When reinstalling the lamp, position its voltage indication to the left side (non-gear end.).

Thermistor

1. Remove the fusing unit. (Refer to Section 3.2.3.6.)
2. Remove the 1 screw (#4), and remove the thermistor.

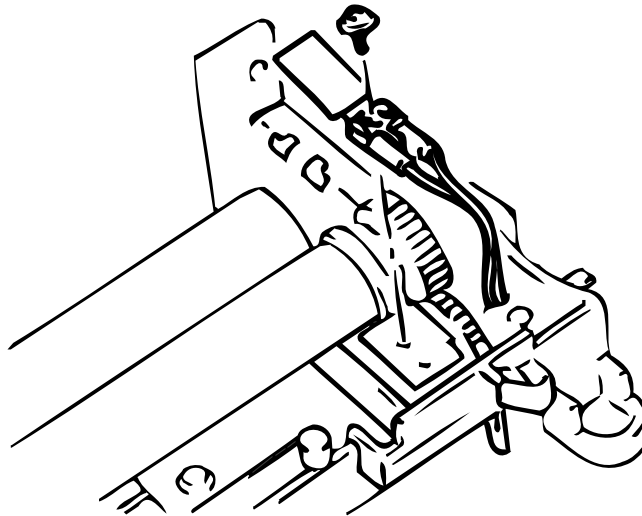

Figure 3-22. Removing the Thermistor

ASSEMBLY POINTS

When reinstalling the thermistor, wire the harness as shown below.

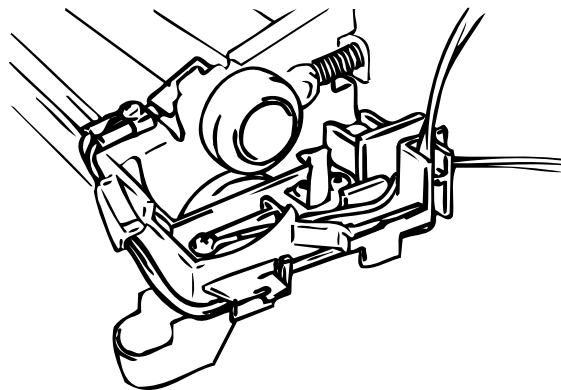

Figure 3-23. Wiring

Paper Separator

1. Remove the fusing unit. (Refer to Section 3.2.3.6.)
2. Release the lock of the holder and remove the 3 paper separator.

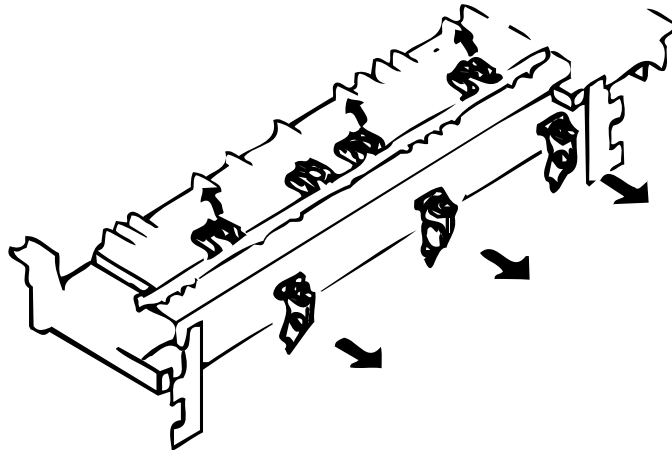

Figure 3-24. Removing the Paper Separator

ASSEMBLY POINTS

When reinstalling the paper separators, be careful of these positions as the middle one differs from others.

Paper Exit Sensor

1. Remove the fusing unit. (Refer to Section 3.2.3.6.)
2. Remove the paper exit sensor.

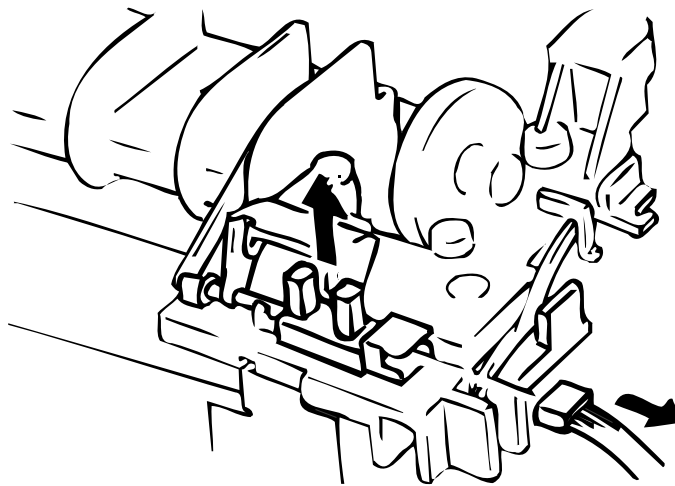

Figure 3-25. Paper Exit Sensor

Fusing Roller

1. Remove the fusing unit. (Refer to Section 3.2.3.6.)
2. Remove the 2 G-rings from the fusing unit.

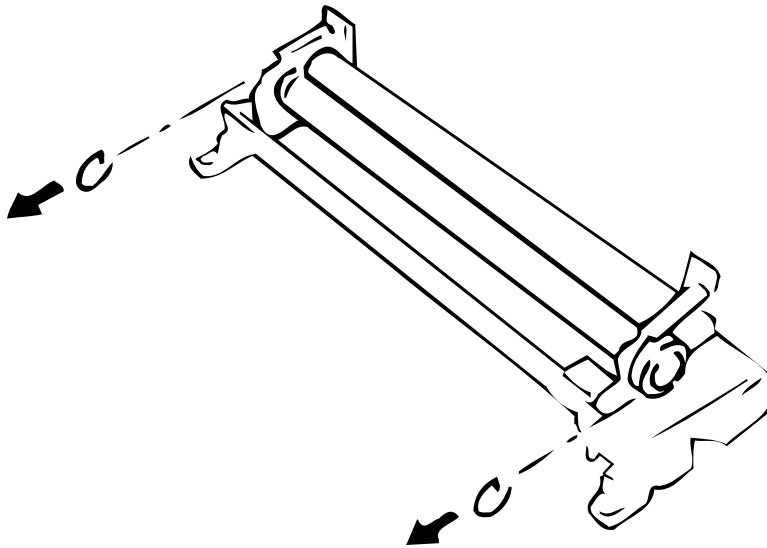

Figure 3-26. Removing the G-Rings

CAUTION**When reinstalling the G-rings:**

- Be careful of the direction.
- Securely position them into the grooves of the fusing roller.

3. Remove the upper fusing roller drive gear.
4. Remove the upper fusing roller.

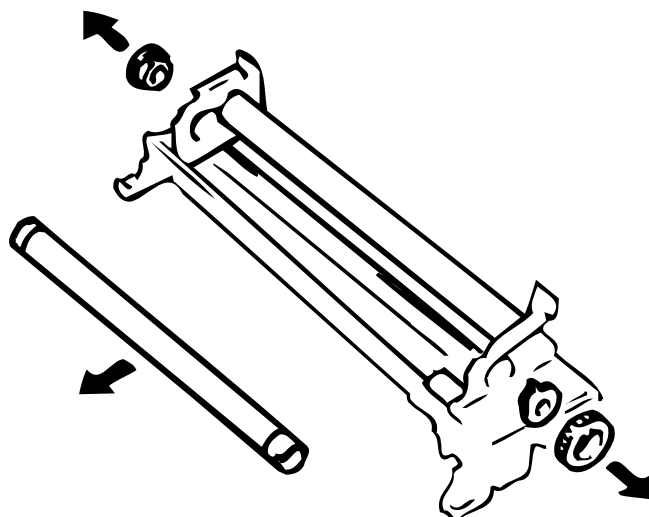

Figure 3-27. Removing the Upper Fusing Roller

5. Take out the lower fusing roller.

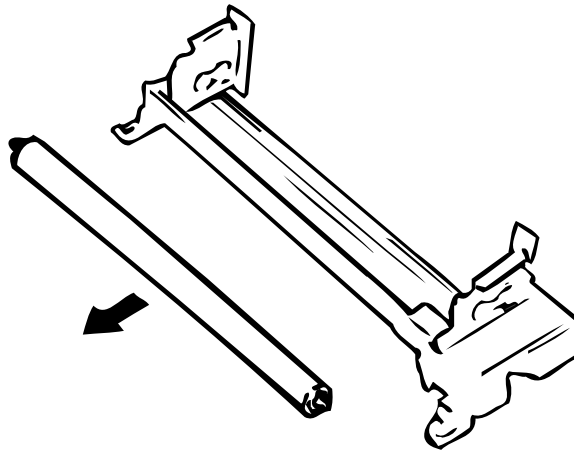

Figure 3-28. Removing the Lower Fusing Roller

Thermal Fuse

1. Remove the fusing unit. (Refer to Section 3.2.3.6.)
2. Remove 2 screws (#5), and remove the thermal fuse.

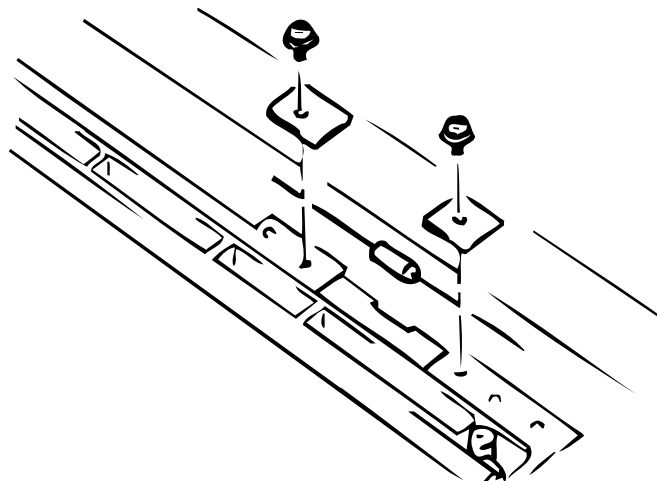

Figure 3-29. Removing the Thermal Fuse

3.2.3.8 Main Motor Removal

1. Remove the housing components. (Refer to Section 3.2.1.1.)
2. Remove 1 screw (#4) which fixing the motor bracket and the 2 screws (#2) which fixing the main motor, and remove the main motor together with the bracket.

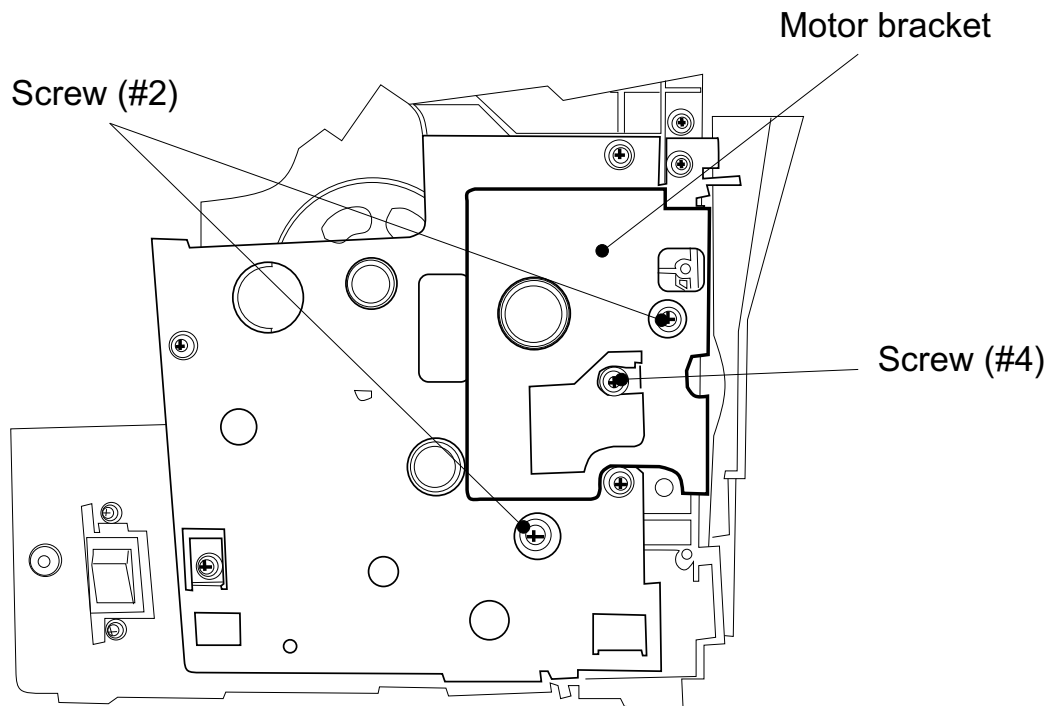

Figure 3-30. Removing the Motor Bracket

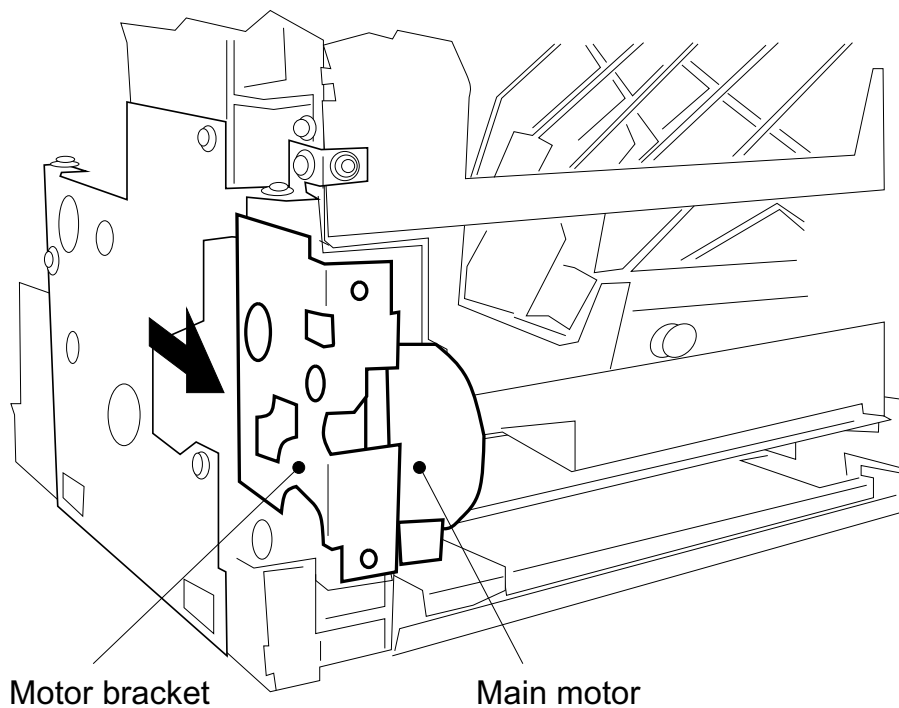

Figure 3-31. Removing the Main Motor

3.2.3.9 Paper Take-Up Sensor and Paper Take-Up Solenoid Removal

1. Remove the housing components. (Refer to Section 3.2.1.1.)
2. Turn over the printer on its back.
3. Remove the 4 screws (#6), and remove the ground plate.
4. Turn up the lifting plate.

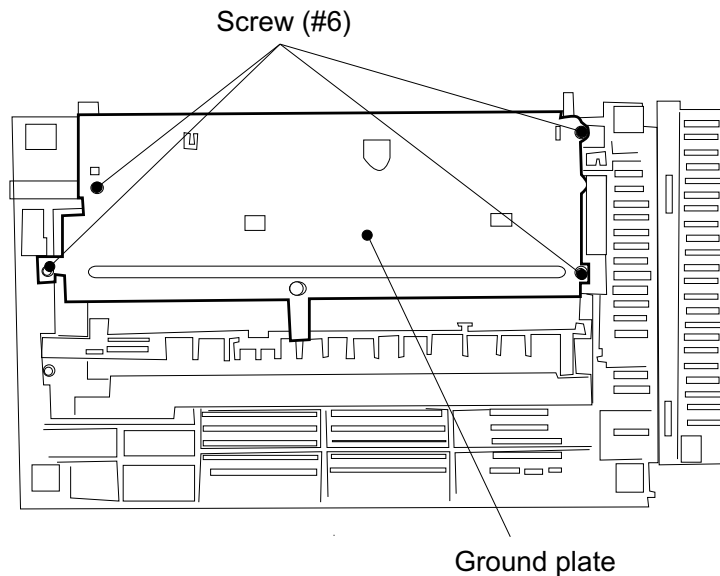

Figure 3-32. Removing the Ground Plate

ASSEMBLY POINT

When turning up the lifting plate, be careful with the grounding plate which overlapping the lifting plate.

5. Remove the 2 screws (#6), and remove the paper guide assembly.
6. Remove the paper take-up sensor and the paper take-up solenoid from the assembly.

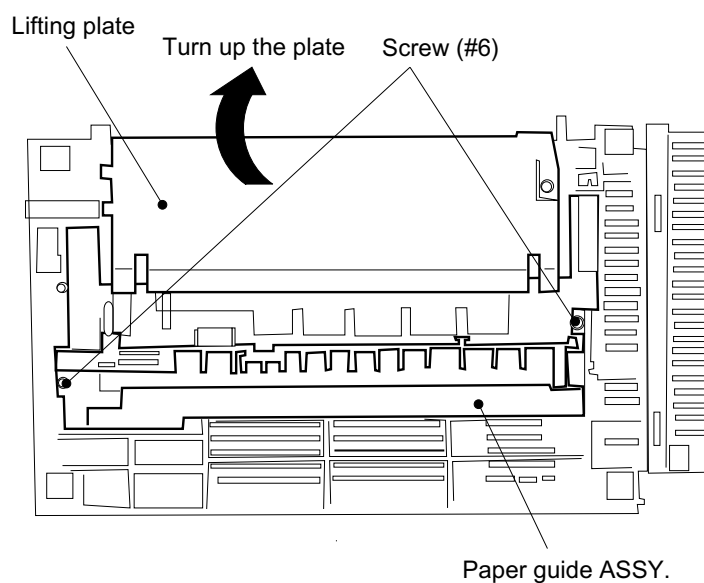

Figure 3-33. Removing the Paper Guide ASSY.

3.2.3.10 Paper Take-Up Roller Removal

1. Remove the main motor. (Refer to Section 3.2.3.8.)
2. Remove the paper guide assembly. (Refer to Section 3.2.3.9.)
3. Remove the 6 screws (#4:2, #5:4), and remove the left frame.
4. Remove the 2 gears (GEAR 29/65T, GEAR 22/57T), specified in the figure below.

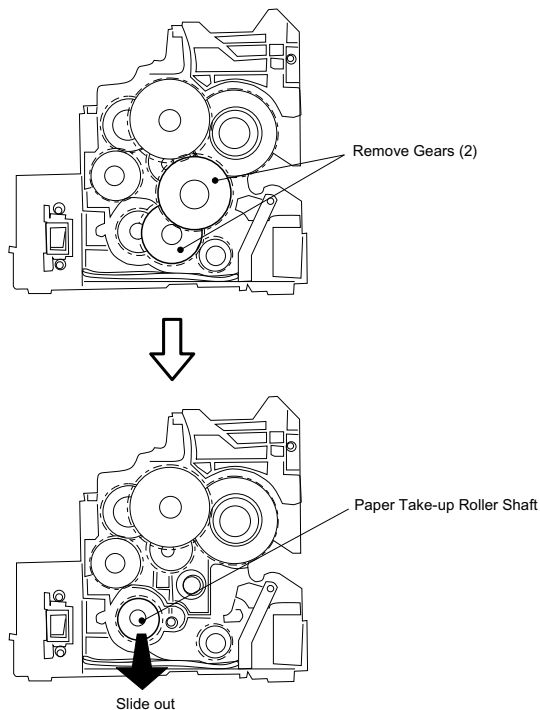

Figure 3-34. Removing the Gears

5. At the bottom of the printer, remove the E-ring fixing the paper take-up roller shaft.
6. Unhook the paper take-up roller and slide the shaft to the end of the shaft where the driven gear is attached, then remove the paper take-up roller.

ASSEMBLY POINT

When removing the paper take-up roller from the shaft, be sure not to lose the pin.

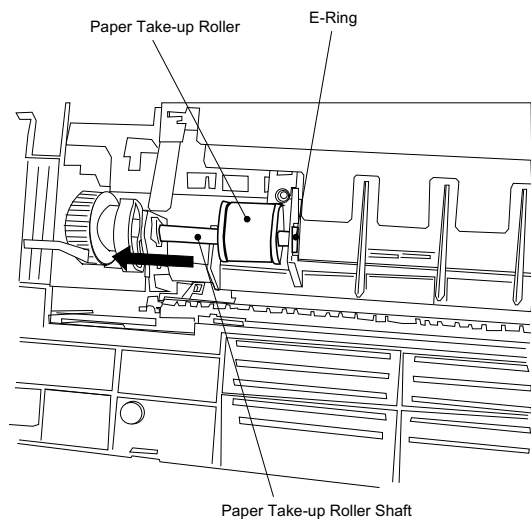

Figure 3-35. Removing the Paper Take-Up Roller

Chapter 4 Adjustment

Table of Contents

4.1 ADJUSTMENT	4-1
4.1.1 Print Position Adjustment	4-1

List of Figures

Figure 4-1. Print Position Adjustment.	4-1
--	-----

4.1 ADJUSTMENTS

This section describes the adjustment procedures for the EPL-5500. You must perform these adjustments after servicing the printer, especially when any component or part is replaced.

4.1.1 Print Position Adjustment

You can adjust the vertical print position on a sheet of paper by turning the image synchronizing volume control on the main board (C169 MAIN-B). After replacing a main board, be sure to adjust the print position using the procedure below.

1. Print a status sheet.
2. Check that the registration gap between the leading edge of the sheet and the horizontal line printed on the page is within the following range:
 29.6 ± 2.5 mm (1.17 ± 0.01 inches) for a status sheet page on A4/letter paper:
 If the gap is not correct, adjust the print position as described in the next few steps.

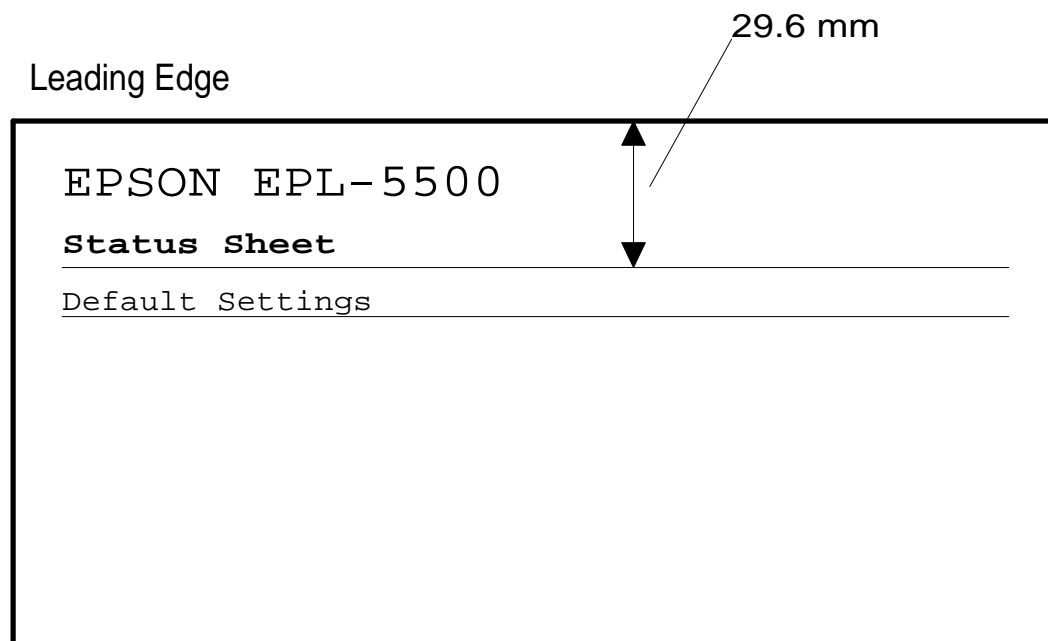

Figure 4-1. Print Position Adjustment

3. Turn printer power off.
4. Open the right cover and shield plate. (See Chapter 3.)
5. Adjust the image synchronizing adjustment volume (VR201) on the main board (C169 MAIN-B) so that the gap for the print position of the horizontal line (down from the top edge of the sheet) becomes 29.6 mm (1.17 inches) .
 - Turn VR201 clockwise to increase the gap for the print position of the horizontal line.
 - Turn VR201 counterclockwise to decrease the gap.
6. Turn on the printer.
7. Print a status sheet again to check the print position.
8. Repeat steps 5 to 7 until the print position is 29.6 mm (1.17 inches).
9. Reattach the shield plate and right case.

Chapter 5 Troubleshooting

Table of Contents

5.1 OVERVIEW	5-1
5.2 SELF-DIAGNOSTIC FUNCTION	5-1
5.2.1 SOFT ERROR	5-1
5.2.2 Service Call Error	5-2
5.3 TROUBLESHOOTING	5-4
5.3.1 Troubleshooting of Abnormal Operation	5-4
5.3.2 Print Quality Anomaly	5-13

List of Tables

Table 5-1. SOFT ERROR Code List	5-1
Table 5-2. Service Call A Error	5-2
Table 5-3. Service Call B Error	5-3
Table 5-4. Symptoms and Reference Tables	5-4
Table 5-5. The Printer Does Not Operate at All	5-5
Table 5-6. Both LED Lights Do Not Come On	5-5
Table 5-7. The LED Does Not Come On (1)	5-5
Table 5-8. The LED Does Not Come On (2)	5-6
Table 5-9. The LED Does Not Come On (3)	5-8
Table 5-10. The LED Does Not Come On (4)	5-9
Table 5-11. Software Errors	5-9
Table 5-12. Fusing Unit Error	5-9
Table 5-13. The Fan Motor Error	5-9
Table 5-14. Scanner Motor Error	5-9
Table 5-15. Laser Light Error	5-10
Table 5-16. Communication Error	5-10
Table 5-17. EEPROM Write Error	5-10
Table 5-18. Engine Initialize Error	5-10
Table 5-19. C1000 or C1001 Error	5-10
Table 5-20. C1002 Error	5-10
Table 5-21. C1003 Error	5-11
Table 5-22. C1130 Error	5-11
Table 5-23. C1170 Error	5-11
Table 5-24. C1180 Error	5-11
Table 5-25. C1300 or C1310 Error	5-11
Table 5-26. C1320 Error	5-12
Table 5-27. C1990 Error	5-12
Table 5-28. Print Quality Anomaly	5-13

5.1 OVERVIEW

The EPL-5500 has a sophisticated, built-in, self-diagnostic function that reduces the troubleshooting time by identifying failed parts or components. This self-diagnostic test identifies the troubleshooting problems for page printers, in which even a trivial failure can result in a serious print quality problem.

5.2 SELF-DIAGNOSTIC FUNCTION

This section describes the self-diagnostic function in which the controller automatically checks the operating conditions of each component. If any abnormality is detected, the printer prints an error message on the status sheet or displays a message with the LED lights.

5.2.1 SOFT ERROR

When the printer detects an error relating to a software operation, the printer indicates it as "SOFT ERROR" by slowly flashing the red LED light. By pressing the button on the control panel, the printer prints the status sheet with error information. Table 5-1 lists the soft error codes.

Table 5-1. SOFT ERROR Code List

Error Code	Error Condition
C0001	CPU error (reserved)
C0002	CPU error (programming command error)
C0003	CPU error (illegal instruction)
C0004	CPU error (unsupported FPU instruction)
C0007	CPU error (address misalignment)
C0009	CPU error (reserved)
C0010	CPU error (tag overflow)
C0017 to 31	CPU error (unsupported interrupt)
C0036	CPU error (unsupported coprocessor instruction)
C0128 to 254	CPU error (unimplemented instruction)
C0255	CPU error (break error)
Axxxx	Software error
Bxxxx	Software error
Dxxxx	Software error
Fxxxx to Zxxxx	Software error

5.2.2 Service Call Error

If the printer detects a fatal error that unrecoverable by the user, the printer indicates it with the LED lights as "Service Call Error". There are two types of "Service Call Error" as explained below, and each error is indicated by the LED lights of the control panel in different manner.

■ Service Call A Errors

Indication: First, yellow and red LED lights go on and off twice alternately. Then, both yellow and red LED lights go on and off a number of times corresponding to the error number in the table 5-2.

Example: "Fan motor error" (error number = 2)

Order	LED (Yellow)	LED (Red)	Interval	State
1	ON	OFF	Short	Service call error indication
2	OFF	ON	Short	
3	ON	OFF	Short	
4	OFF	ON	Short	
5	OFF	OFF	Long	Error code = "2" (LED on for 2 times)
6	ON	ON	Short	
7	OFF	OFF	Short	
8	ON	ON	Short	
9	OFF	OFF	Long	

Table 5-2. Service Call A Error

Error No.	Error Code	Error Condition
1	E0003	Fusing unit error
2	E0005	Fan motor error
3	E0006	Scanner mirror motor error
4	E0009	Laser light error
5	E0014	Communication error for engine controller and video controller
6	C1200	EEPROM write error
7	C1400	Engine initialize error

■ Service call B error

Indication: First, yellow and red LED lights go on and off three times alternately to indicate that the printer start to display "Service Call B Error". The error number of "Service Call B Error" consists of 4 digits number, and each LED light indicates corresponding number from 4th digit to 1st digit in the following order:

Yellow LED: 4th digit (X---)
 Red LED: 3rd digit (-X--)
 Yellow LED: 2nd digit (--X-)
 Red LED: 1st digit (---X)

Note that if any digit of corresponding error number is "0", both yellow and red LED lights go on and off once at the same time.

Example: "Standard ROM error" (error number = 1130)

Order	LED (Yellow)	LED (Red)	Interval	State	
1	ON	OFF	Short	Service Call Error B indication	
2	OFF	ON	Short		
3	ON	OFF	Short		
4	OFF	ON	Short		
5	ON	OFF	Short		
6	OFF	ON	Short		
7	OFF	OFF	Long		Error code = "1130"
8	ON	OFF	Short	4th digit = "1"	
9	OFF	OFF	Long		
10	OFF	ON	Short	3rd digit = "1"	
11	OFF	OFF	Long		
12	ON	OFF	Short	2nd digit = "3"	
13	OFF	OFF	Short		
14	ON	OFF	Short		
15	OFF	OFF	Short		
16	ON	OFF	Short		
17	OFF	OFF	Long		
18	ON	ON	Short	1st digit = "0"	
19	OFF	OFF	Long		

Table 5-3. Service Call B Error

Error No.				Error Code	Error Condition
4	3	2	1		
1	0	0	0	C1000	RAM Validation error
1	0	0	1	C1001	System RAM check error
1	0	0	2	C1002	Standard RAM error
1	0	0	3	C1003	Optional RAM (SIMM) error
1	1	3	0	C1130	Standard ROM error
1	1	7	0	C1170	Optional NLSP fonts ROM error
1	1	8	0	C1180	Optional ROM SIMM error
1	3	0	0	C1300	Optional Type-B I/F error
1	3	1	0	C1310	Unsupported Type-B I/F installed
1	3	2	0	C1320	LocalTalk I/F error
1	9	9	0	C1999	Other hardware error

5.3 TROUBLESHOOTING

This section describes troubleshooting abnormal operations and print quality problems.

5.3.1 Troubleshooting of Abnormal Operation

This section describes how to detect malfunctions, and determine the cause, and it suggests what actions to take for various types of malfunctions. Each paragraph refers you to a detailed troubleshooting table.

Table 5-4. Symptoms and Reference Tables

Symptom	Printer Condition	Reference Table
The printer does not operate at all	The heater lamp in fusing unit does not come on, and so neither LED light is on.	5-5
Yellow and LED lights do not come on	The heater lamp in the fusing unit comes on, but the LED lights are not on.	5-6
LED light is on	The LED light goes on after power on.	5-7
	The LED light goes on when printing starts.	5-8
	The LED light is on when printing starts from the lower paper cassette.	5-9
	Paper jam.	5-10
Software error	The printer indicates a software error on the status sheet.	5-11
Fusing unit error	A fusing unit error is displayed.	5-12
Fan motor error	A fan motor error is displayed.	5-13
Scanner motor error	A scanner motor error is displayed.	5-14
Laser light error	A laser light error is displayed	5-15
Communication error for engine	A communication error is displayed.	5-16
EEPROM write error	An EEPROM write error is displayed.	5-17
Engine initialize error	An engine initialize error is displayed.	5-18
Error code C1000 or C1001	A C1000 or C1001 is displayed.	5-19
Error code C1002	A C1002 is displayed.	5-20
Error code C1003	A C1003 is displayed.	5-21
Error code C1130	A C1130 is displayed.	5-22
Error code C1170	A C1170 is displayed.	5-23
Error code C1180	A C1180 is displayed.	5-24
Error code C1300 or C1310	A C1300 or C1310 is displayed.	5-25
Error code C1320	A C1320 is displayed.	5-26
Error code C1990	A C1990 is displayed.	5-27

Table 5-5. The Printer Does Not Operate at All

Cause	Step	Checkpoint	Finding	Solution
Connector CN207 on the C169 MAIN-B Board may be disconnected.	1	Is connector CN207 on the C169 MAIN-B Board disconnected?	Yes	Connect CN207 on the board.
The fuse on the PWB-E board may be blown.	2	Has the fuse blown on the PWB-E board?	Yes	Replace the fuse.
PWB-E board may be dead.	3	With power on, is there an output of +5 VDC between pin 4 (+) and pin 3 (-) for CN207 on C169 MAIN-B Board?	No	Replace the PWB-E board.
C169 MAIN-B Board may be dead.	4	—	—	Replace the C169 MAIN-B Board.

Table 5-6. Both LED Lights Do Not Come On

Cause	Step	Checkpoint	Finding	Solution
The C169 MAIN-B Board may be dead.	1	If you change the C169 MAIN-B Board, do the LEDs come on?	Yes	Replace the C169 MAIN-B Board.

Table 5-7. The LED Does Not Come On (1)

Cause	Step	Checkpoint	Finding	Solution
The interlock switch lever is bad.	1	Does the switch turn on when the case is closed?	No	Replace the interlock lever.
The interlock switch may be dead.	2	Does the switch toggle? (Check with a multimeter.)	No	Replace the interlock switch.
The PWB-E board may be dead.	3	With power on, is there an output of +24 VDC between pin 1 (+) and pin 2 (-) for CN207 on C169 MAIN-B board?	No	Replace the PWB-E board.
The paper take-up sensor flag position may be incorrect.	4	Is the paper take-up sensor flag position OK?	No	Reposition the paper take-up sensor flag.
The paper exit sensor flag position may be incorrect.	5	Is the paper exit sensor flag position OK?	No	Reposition the paper exit sensor flag.
The paper take-up sensor connector may be disconnected.	6	Is the paper take-up sensor connector disconnected?	Yes	Connect it.
The paper exit sensor connector may be disconnected.	7	Is the paper exit sensor connector disconnected?	Yes	Connect it.
The paper exit sensor may be dead.	8	—	—	Replace it.
The paper take-up sensor may be dead.	9	—	—	Replace it.

Table 5-8. The LED Does Not Come On (2)

Cause	Step	Checkpoint	Finding	Solution
The paper take-up solenoid coil may be open or shorted.	1	Disconnect connector CN203 on the C169 MAIN-B Board and check the coil resistance between pin 5 and pin 6 on the dis-connected cable side of the connector, using a multimeter. Is the resistance approximately 80 ohms?	No	Replace the paper take-up solenoid.
		If the coil is shorted, check the solenoid drive circuit using the procedure below: 1. Set the multimeter for voltage. 2. Place the (-) terminal of the multimeter on pin 5 of connector CN207 on the C169 MAIN-B Board. 3. Place the (+) terminal of the multimeter on pin 6 (GND). With power on, does the multimeter detect any current?	Yes	Replace the paper take-up solenoid and the C169 MAIN-B Board.
Continued on next page				

Table 5-8. The LED Does Not Come On (2) (Continued)

Cause	Step	Checkpoint	Finding	Solution
The main motor coil may be open or shorted.		Disconnect connector CN206 on the C169 MAIN-B Board, and check the coil resistance between: pin 1 and pin 2; pin 3 and pin 4 (2 points total) on the disconnected cable side of the connector, using a multimeter. Pin 1 — Pin 2 Pin 3 — Pin 4 Are the resistances of all four points approximately 10 ohms?	No	Replace the main motor.
	2	If any coil is shorted, check the main motor drive circuit using the following procedure: 1. Set the multimeter to voltage. 2. Place the (-) terminal of the multimeter on pins 1, 2, 3, or 6 of connector CN206 on the C169 MAIN-B board. 3. Place the (+) terminal on pin 2 of connector CN207 of the C169 MAIN-B Board (GND). With power on, does the multimeter detect current?	Yes	Replace the C169 MAIN-B Board.
Paper take-up sensor flag position may be incorrect.	3	Is paper take-up sensor flag position incorrect?	Yes	Reseat the paper take-up sensor flag.
Paper take-up roller may be bad.	4	—	—	Replace the paper take-up roller.

Table 5-9. The LED Does Not Come On (3)

Cause	Step	Checkpoint	Finding	Solution
The standard tray has problems.	1	Is the standard tray OK?	No	Refer to Table 5-8.
The paper take-up solenoid coil for the lower paper cassette may be open or shorted.	2	Disconnect junction connector near the solenoid and check the coil resistance between pin 1 and pin 2 on the disconnected solenoid side of the connector, using a multimeter. Is the resistance approximately 80 ohms?	No	Replace the paper take-up solenoid.
		If the coil is shorted, check the solenoid drive circuit using the following procedure: 1. Set the multimeter to voltage. 2. Place the (–) terminal on pin of connector CN2 on the lower paper cassette board. 3. Place the (+) terminal on of ground of CN1. With power on, does the multimeter detect any current?	Yes	Replace the paper take-up solenoid and circuit board of lower paper cassette.
The paper take-up roller in the lower paper cassette may be bad.	3	—	—	Replace the paper take-up roller.

Table 5-10. The LED Does Not Come On (4)

Cause	Step	Checkpoint	Finding	Solution
The consumables may not be installed.	1	Are the consumables installed?	No	Install the consumables.
The paper take-up roller may be bad.	2	Does paper always jam in paper take-up roller area?	Yes	Replace the paper take-up roller.
The paper feed roller may be bad.	3	Does paper always jam in the paper feed roller area?	Yes	Replace the paper feed roller.
The fusing unit may be bad.	4	Does paper always jam in the fusing unit?	Yes	Replace it.

Table 5-11. Software Errors

Cause	Step	Checkpoint	Finding	Solution
The C169 MAIN-B Board may be bad.	1	—	—	Replace it.

Table 5-12. Fusing Unit Error

Cause	Step	Checkpoint	Finding	Solution
The connector for the thermistor may be disconnected.	1	Is the connector for the thermistor disconnected?	Yes	Connect it.
The C169 MAIN-B Board may be dead.	2	Does the heater lamp remain lit up until the error occurs?	Yes	Replace the C169 MAIN-B Board.
The heater lamp or thermal fuse in the fusing unit may be bad.	3	Does the heater lamp come on at power on?	No	Replace the heater lamp or thermal fuse in the fusing unit.
The PWB-E board may be dead.	4	—	—	Replace the PWB-E board.

Table 5-13. The Fan Motor Error

Cause	Step	Checkpoint	Finding	Solution
Connector CN211 on the C169 MAIN-B Board may be disconnected.	1	Is connector CN211 on the C169 MAIN-B Board disconnected?	Yes	Connect it.
The fan motor may be dead.	2	—	—	Replace it.

Table 5-14. The Scanner Motor Error

Cause	Step	Checkpoint	Finding	Solution
The optical unit may be bad.	1	—	—	Replace the optical unit.
The C169 MAIN-B Board may be bad.	2	—	—	Replace the C169 MAIN-B Board.

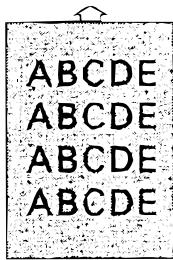
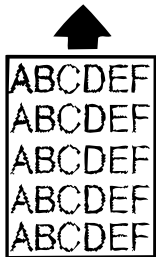

Table 5-15. Laser Light Error

Cause	Step	Checkpoint	Finding	Solution
The optical unit may be dead.	1	—	—	Replace the optical unit.
The C169 MAIN-B Board may be bad.	2	—	—	Replace the C169 MAIN-B Board.

Table 5-16. Communication Error

Cause	Step	Checkpoint	Finding	Solution
The C169 MAIN-B Board may be bad.	1	—	—	Replace the C169 MAIN-B Board.

Table 5-17. EEPROM Write Error

Cause	Step	Checkpoint	Finding	Solution
The EEPROM may be bad.	1	—	—	Replace the EEPROM.
The C169 MAIN-B Board may be bad.	2	—	—	Replace the C169 MAIN-B Board.

Table 5-18. Engine Initialize Error

Cause	Step	Checkpoint	Finding	Solution
The C169 MAIN-B Board may be bad.	1	—	—	Replace the C169 MAIN-B Board.

Table 5-19. C1000 or C1001 Error

Cause	Step	Checkpoint	Finding	Solution
The C1000 or C1001 may be bad.	1	Is operation OK after you remove the optional SIMM?	Yes	Replace the SIMM.
The C169 MAIN-B Board may be bad.	2	—	—	Replace the C169 MAIN-B Board.

Table 5-20. C1002 Error

Cause	Step	Checkpoint	Finding	Solution
The C169 MAIN-B Board may be bad.	1	—	—	Replace the C169 MAIN-B Board.

Table 5-21. C1003 Error

Cause	Step	Checkpoint	Finding	Solution
The optional SIMM may be bad.	1	Is the operation OK after you remove the optional SIMM?	Yes	Replace the SIMM.
The C169 MAIN-B Board may be bad.	2	—	—	Replace the C169 MAIN-B Board.

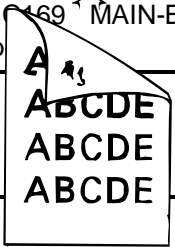

Table 5-22. C1130 Error

Cause	Step	Checkpoint	Finding	Solution
The program ROMs on the C169 MAIN-B Board may be bad.	1	Is operation OK after you replace the ROM?	—	Replace the program ROMs on the C169 MAIN-B Board.
The C169 MAIN-B Board may be bad.	2	—	—	Replace the C169 MAIN-B Board.

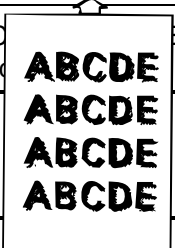

Table 5-23. C1170 Error

Cause	Step	Checkpoint	Finding	Solution
The ROM (IC11) on the C169 MAIN-B Board may be bad.	1	Is operation OK after you replace the ROM?	—	Replace the ROM (IC11) on the C169 MAIN-B Board.
The C169 MAIN-B Board may be bad.	2	—	—	Replace the C169 MAIN-B Board.

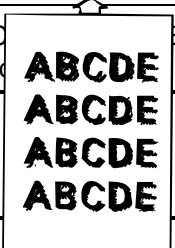

Table 5-24. C1180 Error

Cause	Step	Checkpoint	Finding	Solution
The ROM SIMM may be bad.	1	Is operation OK after you replace the ROM SIMM?	—	Replace the ROM SIMM.
The C169 MAIN-B Board may be bad.	2	—	—	Replace the C169 MAIN-B Board.

Table 5-25. C1300 or C1310 Error

Cause	Step	Checkpoint	Finding	Solution
The optional interface card (Type-B) may be bad.	1	—	—	Replace the optional interface card or Type-B EX box.
The C169 MAIN-B Board may be bad.	2	—	—	Replace the C169 MAIN-B Board.

Table 5-26. C1320 Error

Cause	Step	Checkpoint	Finding	Solution
The optional interface card may be bad.	1	—	—	Replace the optional interface card.
The C169 MAIN-B Board may be bad.	2	—	—	Replace the C169 MAIN-B Board.

Table 5-27. C1990 Error

Cause	Step	Checkpoint	Finding	Solution
The C169 MAIN-B Board may be bad.	1	—	—	Replace the C169 MAIN-B Board.

5.4.2 Print Quality Anomalies

This section describes how to isolate possible causes of a print quality problem .

Table 5-28. Print Quality Anomalies

Symptom	Possible Cause	Part Name	Check Item	Remedy
Low image density	Poor development	PWB-F board	—	Replace the PWB-F board.
	Image transfer problem	Image transfer unit	Check to see if the surface of image transfer unit is damaged.	Replace the image transfer unit.
		PWB-F board	—	Replace the PWB-F board.
	Defective PC drum	Photoconductor unit	—	Replace the photoconductor unit.
	Improper print density setting	—	—	Adjust the print density using printer settings.
Foggy background	Poor development	Toner cartridge	—	Replace the toner cartridge.
	Improper charging	Drum charge	—	Replace the PWB-F board.
			Check the wiring of the PC drum charging bias line.	Replace the photoconductor unit.
Improper print density setting	—	—	Adjust the print density in printer settings.	

Table 5-28. Print Quality Anomalies (Continued)

Symptom	Possible Cause	Part Name	Check Item	Remedy
Blank print	Poor development	Imaging cartridge	Check whether the toner cartridge is installed properly.	Reinstall the toner cartridge.
		PWB-F board	—	Replace the PWB-F board.
	Improper charging	PWB-F board	—	Replace the PWB-F board.
	Poor image transfer	Image transfer unit	Check the surface of the image transfer unit.	Replace the image transfer unit.
		PWB-F board	—	Replace the PWB-F board.
	Improper print density setting	—	—	Adjust the print density in SelecType.
Defective optical unit	Optical unit	—	Replace the optical unit.	
Black print	Improper charging	Photoconductor unit	—	Replace the photoconductor unit.
		PWB-F board	—	Replace the PWB-F board.
	Poor development	Toner cartridge	—	Replace the toner cartridge.
		PWB-F board	—	Replace the PWB-F board.
	Improper print density setting	—	—	Adjust the print density in SelecType
	Defective optical unit	Optical unit	—	Replace the optical unit.
White/black lines and bands.	Improper charging	Photoconductor unit	—	Replace the imaging cartridge.
	Poor development	PWB-F board	—	Replace the PWB-F board.
		Toner cartridge	—	Replace the toner cartridge.
	Dirt on the fusing roller	Fusing roller	—	Clean the fusing roller.

Table 5-28. Print Quality Anomalies (Continued)

Symptom	Possible Cause	Part Name	Check Item	Remedy
Toner smudges on the back side of the sheet.	Improper charging	PWB-F	—	Replace the PWB-F board.
	Poor development	PWB-F	—	Replace the PWB-F board.
	Improper fusing	Fusing unit	—	Replace the fusing unit.
Offset print	Improper fusing	Fusing unit	—	Replace the fusing unit.
White spots	Poor image transfer	Image transfer unit	—	Replace the image transfer unit.
		PWB-F	—	Replace the PWB-F board.

Chapter 6 Maintenance

Table of Contents

6.1 MAINTENANCE	6-1
6.1.1 User Maintenance	6-1
6.1.1.1 Cleaning	6-1
6.1.1.2 Replacement of Consumables	6-2
6.1.2 Service Maintenance	6-2
6.1.2.1 Periodic Service Maintenance	6-2
6.1.2.2 Cleaning	6-2

List of Figures

Figure 6-1. Position of the Special Tool	6-1
Figure 6-2. Cleaning the Electrode Comb	6-1

List of Tables

Table 6-1. Periodic Service Maintenance	6-2
Table 6-2. Cleaning Parts and Procedures	6-2

6.1 MAINTENANCE

The EPL-5500 is a page printer that uses an electrophotographic printing method. Unlike most impact or ink-jet printers, the key components in the electrophotographic process are integrated into two expendable units (the photoconductor unit and toner cartridge). Therefore, periodic replacement of them is essential to ensure high-quality output. Other maintenance items are also described in this chapter, which is divided into two sections: user maintenance (preventive maintenance) and service maintenance (repair).

6.1.1 User Maintenance

Users can achieve maximum print quality from the printer by following the procedures below:

6.1.1.1 Cleaning

This section describes the cleaning required for optimal print quality.

□ External Cleaning

Be sure to disconnect the printer from the power outlet before cleaning it. Wipe the cover and external parts of the printer with a damp cloth that has been soaked in a neutral cleaning solution.

□ Internal Cleaning

Be sure the printer has been disconnected from the power supply and that the fusing unit has cooled down. If the electrode comb of the image transfer unit is dirty, clean it with a special tool, using the following steps:

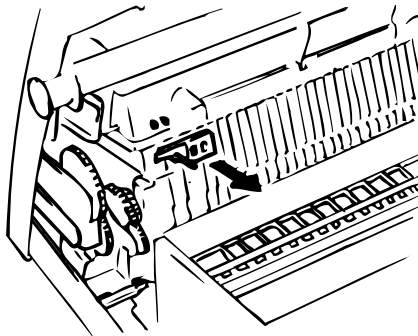

Figure 6-1. Position of the Special Tool

1. Pick up the electrode comb cleaner from the upper unit.
2. Wipe the electrode comb surface from end to end with the electrode comb cleaner several times.

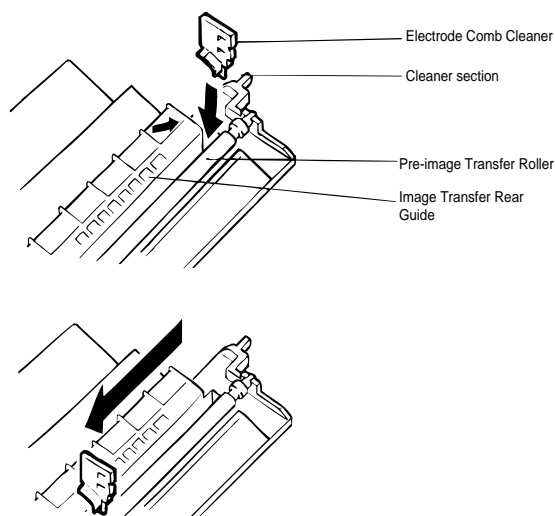

Figure 6-2. Cleaning the Electrode Comb

6.1.1.2 Replacement of Consumables

This printer uses a consumable photoconductor unit and toner cartridge. The life of photoconductor unit is 20,000 pages and the toner cartridge life is 3,000 pages, when printing on A4- or letter-size pages with a 5% print ratio.

If printed images become faint, remove the toner cartridge and gently shake it. This will distribute the toner and may make the images darker. If the image is still too light, replace the toner cartridge.

If the printed image remains faint after you have replaced the toner cartridge, change the photoconductor unit.

6.1.2 Service Maintenance

This section describes the periodic service maintenance and the cleaning required.

6.1.2.1 Periodic Service Maintenance

The following units need service maintenance periodically, because they are subject to functional deterioration as the total number of printed pages increases, resulting in bad print quality.

Table 6-1. Periodic Service Maintenance

Unit	Service Interval
Image transfer unit	Approx. 50,000 pages
Fusing unit	Approx. 50,000 pages

The service interval listed above is only a reference value. You do not need to perform service maintenance exactly at this time.

6.1.2.2 Cleaning

Some parts of this printer require regular cleaning. Clean each part using the specified method and tools. (Refer to Chapter 3 for disassembly procedures.)

Table 6-2. Cleaning Parts and Procedures

Parts Name	Cleaning Procedure
Paper take-up roller	Wipe the surface with a dry soft cloth.
Upper fusing roller (in fusing unit)	Dip a soft cloth in silicon oil and wipe the dust off.
Lower fusing roller (in fusing unit)	
Thermistor (in fusing unit)	Dip a soft cloth in denatured alcohol and wipe the dust off.
Paper separator and rollers (in fusing unit)	

Appendix A Reference Materials

Table of Contents

A.1 CONNECTOR PIN ASSIGNMENTS	A-1
A.1.1 Main Board (C169 MAIN-B Board)	A-4
A.2 CIRCUIT DIAGRAM	A-11
A.3 CIRCUIT BOARD COMPONENT LAYOUT	A-16

List of Figures

Figure A-1. Cable Connections for the Video Controller	A-1
Figure A-2. Cable Connections for the Engine Controller	A-2
Figure A-3. C169 MAIN-B Circuit Diagram (1/2)	A-11
Figure A-4. C169 MAIN-B Circuit Diagram (2/2)	A-13
Figure A-5. PWB-E (120V) Circuit Diagram	A-14
Figure A-6. PWB-E (220/240V) Circuit Diagram	A-15
Figure A-7. C169 MAIN-B Component Layout (Front)	A-16
Figure A-8. C169 MAIN-B Component Layout (Rear)	A-17

List of Tables

Table A-1. Board Connector Summary	A-3
Table A-2. CN2 Pin Assignments	A-4
Table A-3. CN4 Pin Assignments	A-5
Table A-4. CN5 Pin Assignments	A-7
Table A-5. CN202 Pin Assignments	A-8
Table A-6. CN203 Pin Assignments	A-8
Table A-7. CN204 Pin Assignments	A-9
Table A-8. CN205 Pin Assignments	A-9
Table A-9. CN206 Pin Assignments	A-9
Table A-10. CN207 Pin Assignments	A-9
Table A-11. CN208 Pin Assignments	A-9
Table A-12. CN209 Pin Assignments	A-10
Table A-13. CN210 Pin Assignments	A-10
Table A-14. CN211 Pin Assignments	A-10

A.1 CONNECTOR PIN ASSIGNMENTS

Figures A-1 and A-2 illustrate the interconnection of the primary components. Table A-1 gives the size and a description of each connector.

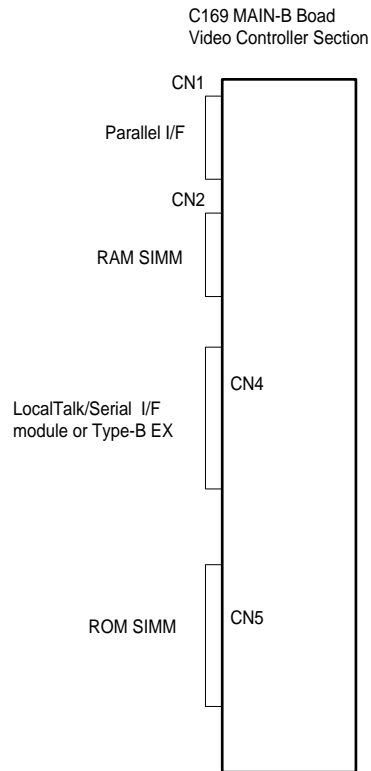

Figure A-1. Connections for the Video Controller

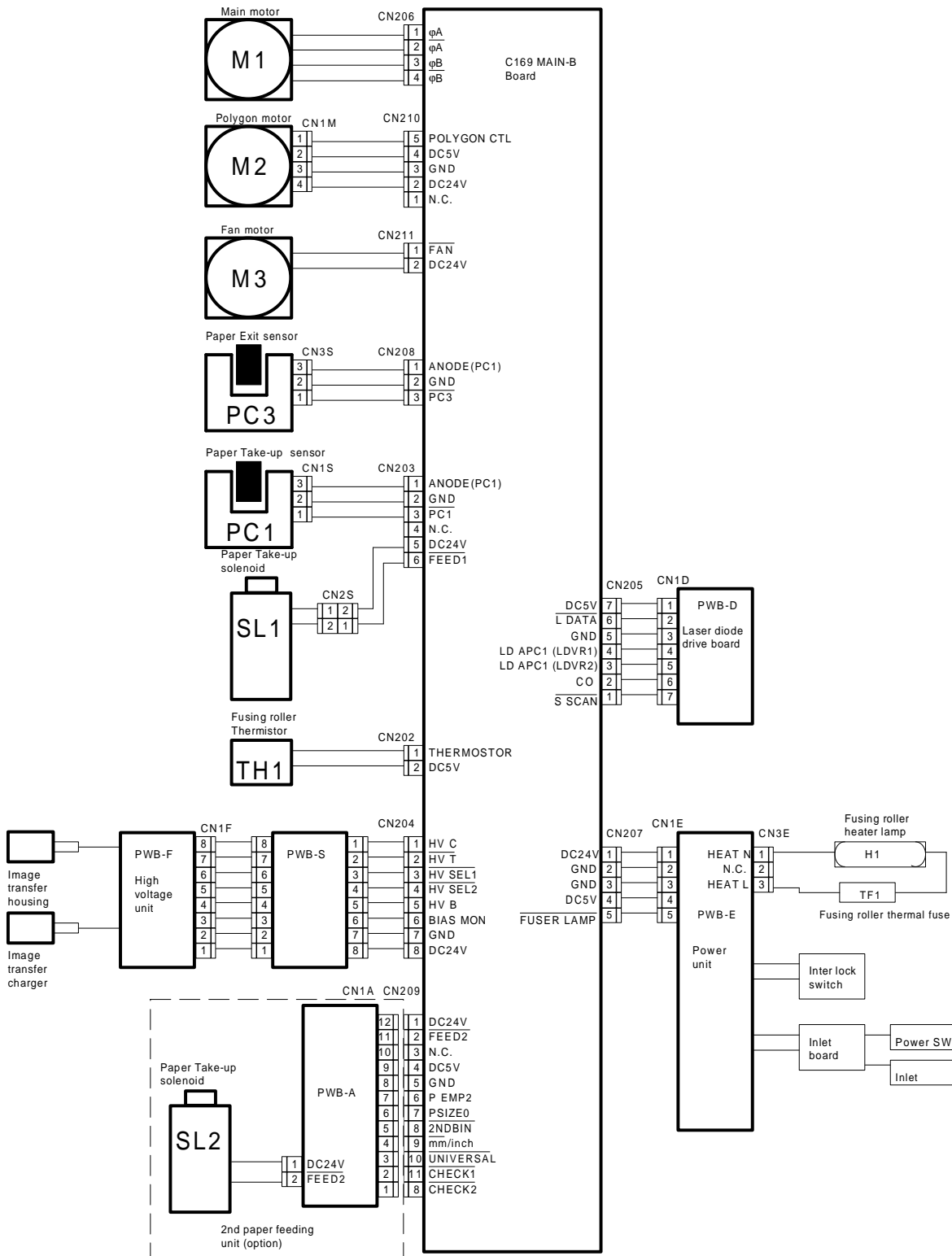

Figure A-2. Cable Connections for the Engine Controller

Table A-1. Board Connector Summary

Connector	Description	Pins	Reference
Main Board (C169 MAIN-B Board)			
CN1	Centronics parallel interface	36 pins	Table 1-8
CN2	Connector for RAM SIMM	72 pins	Table A-2
CN3	(Not used)	20 pins	—
CN4	Connector for LocalTalk/Serial I/F Module or Type-B EX	60 pins	Table A-3
CN5	Connector for ROM SIMM	72 pins	Table A-4
CN6	(Not used)	80 pins	—
CN7	(Not used)	40 pins	—
CN202	Connector for thermistor	2 pins	Table A-5
CN203	Connector for paper take-up solenoid and paper take-up sensor	6 pins	Table A-6
CN204	Connector for high-voltage supply board (PWB-S and PWB-F board)	8 pins	Table A-7
CN205	Connector for optical unit	7 pins	Table A-8
CN206	Connector for motor	4 pins	Table A-9
CN207	Connector for power supply board (PWB-E board)	5 pins	Table A-10
CN208	Connector for paper exit sensor	3 pins	Table A-11
CN209	Connector for lower paper cassette	12 pins	Table A-12
CN210	Connector for optical unit	5 pins	Table A-13
CN211	Connector for fan	2 pins	Table A-14
Power Supply Board (PWB-E Board)			
CN1	Connector for AC power inlet	4 pins	—
CN2	Connector for main board	5 pin	Table A-11
CN3	Connector for heater lamp	3 pins	—
High-Voltage Supply Board (PWB-F Board)			
CN1	Connector for main board	8 pins	Table A-7
CN2	Connector for paper take-up sensor	3 pins	—

A.1.1 Main Board (C169 MAIN-B Board)

Table A-2. CN2 Pin Assignments

Pin No.	Signal Name	I/O	Description
1	Vss	—	Ground
2	DQ0	I/O	Data bus bit 0
3	DQ16	I/O	Data bus bit 16
4	DQ1	I/O	Data bus bit 1
5	DQ17	I/O	Data bus bit 17
6	DQ2	I/O	Data bus bit 2
7	DQ18	I/O	Data bus bit 18
8	DQ3	I/O	Data bus bit 3
9	DQ19	I/O	Data bus bit 19
10	Vcc	—	+5 VDC
11	NC	—	Not connected
12	MA0	O	Memory address bit 0
13	MA1	O	Memory address bit 1
14	MA2	O	Memory address bit 2
15	MA3	O	Memory address bit 3
16	MA4	O	Memory address bit 4
17	MA5	O	Memory address bit 5
18	MA6	O	Memory address bit 6
19	MA10	O	Memory address bit 10
20	DQ4	I/O	Data bus bit 4
21	DQ20	I/O	Data bus bit 20
22	DQ5	I/O	Data bus bit 5
23	DQ21	I/O	Data bus bit 21
24	DQ6	I/O	Data bus bit 6
25	DQ22	I/O	Data bus bit 22
26	DQ7	I/O	Data bus bit 7
27	DQ23	I/O	Data bus bit 23
28	MA7	O	Memory address bit 7
29	NC	—	Not connected
30	Vcc	—	+5 VDC
31	MA8	O	Memory address bit 8
32	MA9	O	Memory address bit 9
33	<u>RAS3</u>	O	RAS 3
34	<u>RAS2</u>	O	RAS 2
35	MP2	—	Not used
36	MP0	—	Not used
37	MP1	—	Not used
38	MP3	—	Not used
39	Vss	—	Ground
40	<u>CAS0</u>	O	CAS 0
41	<u>CAS2</u>	O	CAS 2
42	<u>CAS3</u>	O	CAS 3
43	<u>CAS1</u>	O	CAS 1
44	<u>RAS0</u>	O	RAS 0
45	<u>RAS1</u>	O	RAS 1
46	NC	—	Not connected
47	<u>WE</u>	O	Write enable
48	NC	—	Not connected
49	DQ8	I/O	Data bus bit 8

Table A-2. CN2 Pin Assignments (Continued)

Pin No.	Signal Name	I/O	Description
50	DQ24	I/O	Data bus bit 24
51	DQ9	I/O	Data bus bit 9
52	DQ25	I/O	Data bus bit 25
53	DQ10	I/O	Data bus bit 10
54	DQ26	I/O	Data bus bit 26
55	DQ11	I/O	Data bus bit 11
56	DQ27	I/O	Data bus bit 27
57	DQ12	I/O	Data bus bit 12
58	DQ28	I/O	Data bus bit 28
59	Vcc	—	+5 VDC
60	DQ29	I/O	Data bus bit 29
61	DQ13	I/O	Data bus bit 13
62	DQ30	I/O	Data bus bit 30
63	DQ14	I/O	Data bus bit 14
64	DQ31	I/O	Data bus bit 31
65	DQ14	I/O	Data bus bit 14
66	NC	—	Not connected
67	PO1	—	Not used
68	PO2	—	Not used
69	PO3	—	Not used
70	PO4	—	Not used
71	NC	—	Not connected
72	Vss	—	Ground

Table A-3. CN4 Pin Assignments

Pin No.	Signal Name	I/O	Description
1	PCLK	O	Clock
2	RST	O	Reset signal
3	GND	—	Ground
4	GND	—	Ground
5	GND	—	Ground
6	GND	—	Ground
7	DB0	I/O	Data bus bit 0
8	DB1	I/O	Data bus bit 1
9	DB2	I/O	Data bus bit 2
10	DB3	I/O	Data bus bit 3
11	DB4	I/O	Data bus bit 4
12	DB5	I/O	Data bus bit 5
13	DB6	I/O	Data bus bit 6
14	DB7	I/O	Data bus bit 7
15	AB0	O	Address bus bit 0
16	AB1	O	Address bus bit 1
17	AB2	O	Address bus bit 2
18	AB3	O	Address bus bit 3
19	AB4	O	Address bus bit 4
20	CS	O	Select signal

Table A-3. CN4 Pin Assignments (Continued)

Pin No.	Signal Name	I/O	Description
21	RD	O	Read strobe signal
22	WR	O	Write strobe signal
23	IREQ	O	Interrupt to option
24	NMI	O	Non-maskable interrupt
25	DREQ	O	Data request
26	DTCT	I	LT option used/unused
27	VCC	—	+5 VDC
28	VCC	—	+5 VDC
29	VCC	—	+5 VDC
30	VCC	—	+5 VDC
31	TXD+	—	Not used
32	TXD-	—	Not used
33	RXD+	—	Not used
34	RXD-	—	Not used
35	DTR	—	Not used
36	CTS	—	Not used
37	NC	—	Not used
38	NC	—	Not used
39	LCD	—	Not used
40	SWRD	—	Not used
41	GND	—	Ground
42	GND	—	Ground
43	GND	—	Ground
44	GND	—	Ground
45	RESET	O	Reset signal
46	INH	O	I/F disabled
47	CMREQ	I	Request command
48	WRRDY	I	I/F ready
49	RDREQ	I	Data read request
50	WRT	O	Write enable
51	RDT	O	Read enable
52	TYPB	I	Type-B I/F used/unused
53	TXD	—	Not used
54	READY	—	Not used
55	RXD	—	Not used
56	NC	—	Not connected
57	VCC	—	+5 VDC
58	VCC	—	+5 VDC
59	VCC	—	+5 VDC
60	VCC	—	+5 VDC

Table A-4. CN5 Pin Assignments

Pin No.	Signal Name	I/O	Description
1	Vss	—	Ground
2	D0	I/O	Data bus bit 0
3	D16	I/O	Data bus bit 16
4	D1	I/O	Data bus bit 1
5	D17	I/O	Data bus bit 17
6	D2	I/O	Data bus bit 2
7	D18	I/O	Data bus bit 18
8	D3	I/O	Data bus bit 3
9	D19	I/O	Data bus bit 19
10	Vcc	—	+5 VDC
11	RD	O	Read strobe
12	A0	O	Address bit 0
13	A1	O	Address bit 1
14	A2	O	Address bit 2
15	A3	O	Address bit 3
16	A4	O	Address bit 4
17	A5	O	Address bit 5
18	A6	O	Address bit 6
19	A10	O	Address bit 10
20	D4	I/O	Data bus bit 4
21	D20	I/O	Data bus bit 20
22	D5	I/O	Data bus bit 5
23	D21	I/O	Data bus bit 21
24	D6	I/O	Data bus bit 6
25	D22	I/O	Data bus bit 22
26	D7	I/O	Data bus bit 7
27	D23	I/O	Data bus bit 23
28	A7	O	Address bit 7
29	A19	O	Address bit 19
30	Vcc	—	+5 VDC
31	A8	O	Address bit 8
32	A9	O	Address bit 9
33	A20	O	Address bit 20
34	EEP	O	Chip select
35	RESET	O	Reset signal
36	A21	O	Address bit 21
37	A22	O	Address bit 22
38	A23	O	Address bit 23
39	Vss	—	Ground
40	A11	O	Address bit 11
41	A13	O	Address bit 13
42	A14	O	Address bit 14
43	A12	O	Address bit 12
44	CS0	O	Chip select
45	CS1	O	Chip select
46	A18	O	Address bit 18
47	WR	O	Write enable
48	A17	O	Address bit 17
49	D8	I/O	Data bus bit 8

Table A-4. CN5 Pin Assignments (Continued)

Pin No.	Signal Name	I/O	Description
50	D24	I/O	Data bus bit 24
51	D9	I/O	Data bus bit 9
52	D25	I/O	Data bus bit 25
53	D10	I/O	Data bus bit 10
54	D26	I/O	Data bus bit 26
55	D11	I/O	Data bus bit 11
56	D27	I/O	Data bus bit 27
57	D12	I/O	Data bus bit 12
58	D28	I/O	Data bus bit 28
59	Vcc	—	+5 VDC
60	D29	I/O	Data bus bit 29
61	D13	I/O	Data bus bit 13
62	D30	I/O	Data bus bit 30
63	D14	I/O	Data bus bit 14
64	D31	I/O	Data bus bit 31
65	D14	I/O	Data bus bit 14
66	A16	O	Address bit 7
67	R/B	—	Not used
68	NC	—	Not connected
69	NC	—	Not connected
70	NC	—	Not connected
71	A15	O	Address bit 15
72	Vss	—	Ground

Table A-5. CN202 Pin Assignments

Pin No.	Signal Name	I/O	Description
1	+5	—	+5 VDC
2	TH	I	Fuser temperature

Table A-6. CN203 Pin Assignments

Pin No.	Signal Name	I/O	Description
1	PS1	I	Paper take-up sensor
2	GND1	—	Ground
3	PS1	I	Paper take-up sensor
4	NC	—	No connected
5	+24V	—	+24 VDC
6	FEED1	O	Paper take-up solenoid drive

Table A-7. CN204 Pin Assignments

Pin No.	Signal Name	I/O	Description
1	HV-C	—	
2	HV-T	I	
3	HV-S	—	
4	HV-S2	—	
5	HV-B	—	
6	BIAS-M	O	
7	GND2	—	Ground
8	+24	—	+24 VDC

Table A-8. CN205 Pin Assignments

Pin No.	Signal Name	I/O	Description
1	SSCAN	I	Horizontal synchronous signal
2	LD-CTL	I	Laser power signal
3	LDAPC2	O	Laser power adjust 2
4	LDAPC1	O	Laser power adjust 1
5	GND1	—	Ground
6	LDATA	O	Laser data
7	+5V	—	+5 VDC

Table A-9. CN206 Pin Assignments

Pin No.	Signal Name	I/O	Description
1	A	O	Motor phase A
2	A	O	Motor phase A
3	B	O	Motor phase B
4	B	O	Motor phase B

Table A-10. CN207 Pin Assignments

Pin No.	Signal Name	I/O	Description
1	+24V	—	+24 VDC
2	GND2	—	Ground
3	GND1	—	Ground
4	+5V	—	+5 VDC
5	FUSER	O	Heater lamp on

Table A-11. CN208 Pin Assignments

Pin No.	Signal Name	I/O	Description
1	PS3	I	Paper exit sensor (+5V)
2	GND	—	Ground
3	PS3	I	Paper exit sensor (SGL)

Table A-12. CN209 Pin Assignments

Pin No.	Signal Name	I/O	Description
1	+24 V	—	+24 VDC
2	FEED2	O	Lower cassette solenoid on
3	NC	—	No connected
4	+5V	—	+5 VDC
5	GND1	—	Ground
6	PE2	I	Lower cassette paper empty
7	PSIZ0		
8	PSIZ1		
9	PSIZE2		
10	CHECK1		
11	CHECK2		
12	CHECK3		

Table A-13. CN210 Pin Assignments

Pin No.	Signal Name	I/O	Description
1	NC	—	Not connected
2	+24V	—	+24 VDC
3	GND2	—	Ground
4	+5V	—	+5 VDC
5	P-CTL	O	Polygon motor control

Table A-14. CN211 Pin Assignments

Pin No.	Signal Name	I/O	Description
1	+24V	—	+24 VDC
2	FAN	O	Fan control

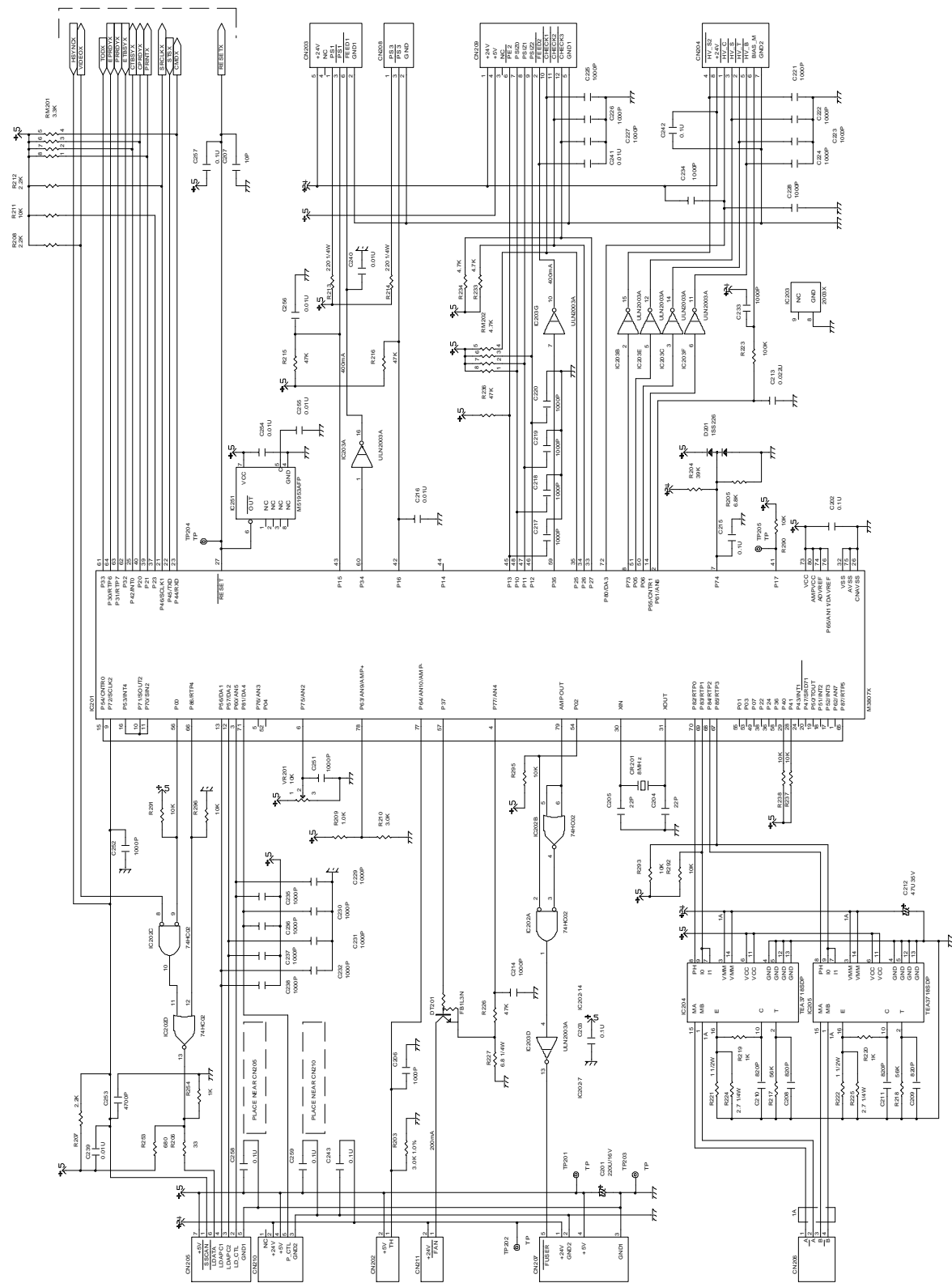

Figure A-4. C169 MAIN-B Circuit Diagram (2/2)

A.3 CIRCUIT BOARD COMPONENT LAYOUT

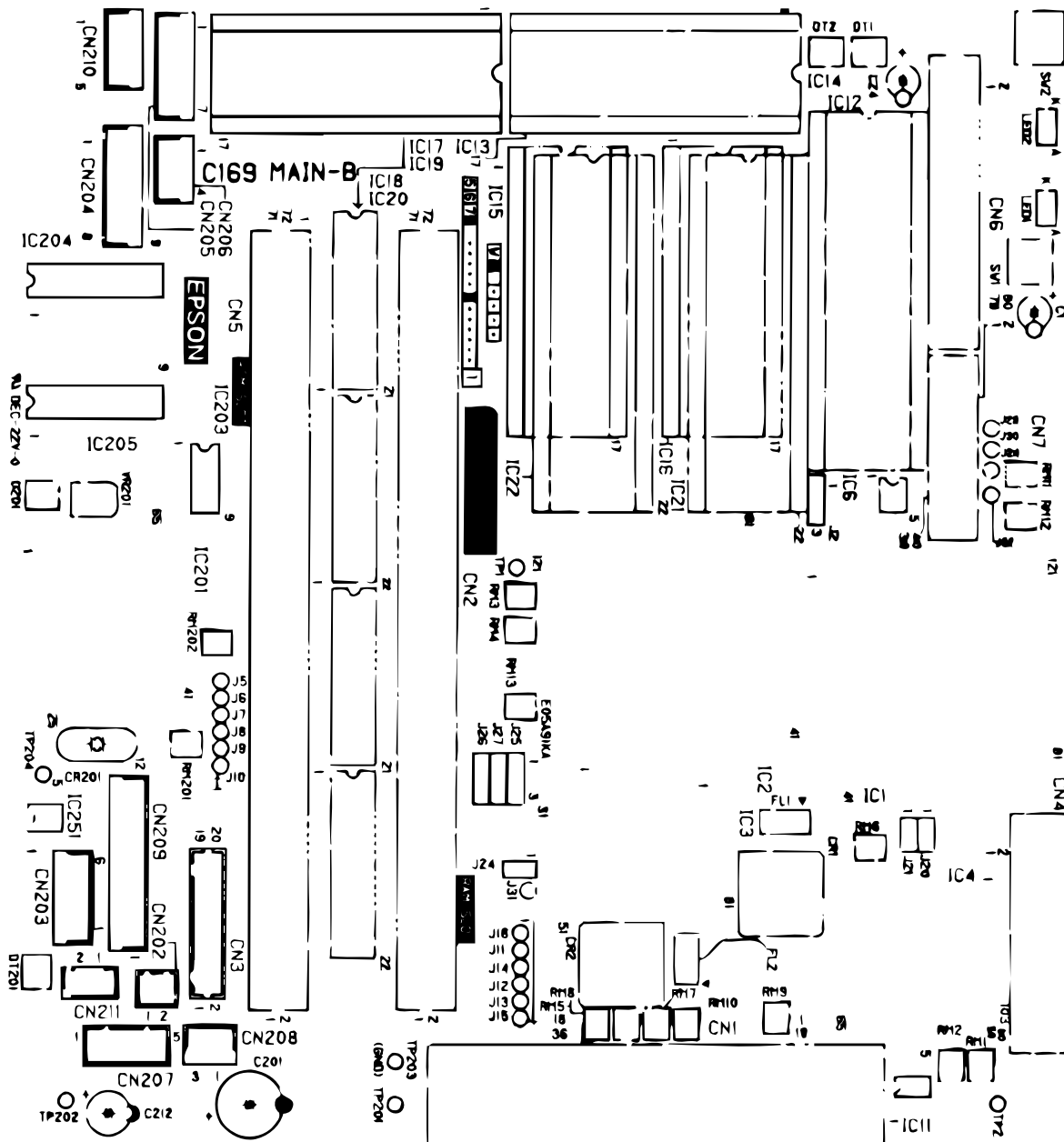

Figure A-7. C169 MAIN-B Component Layout (Front)

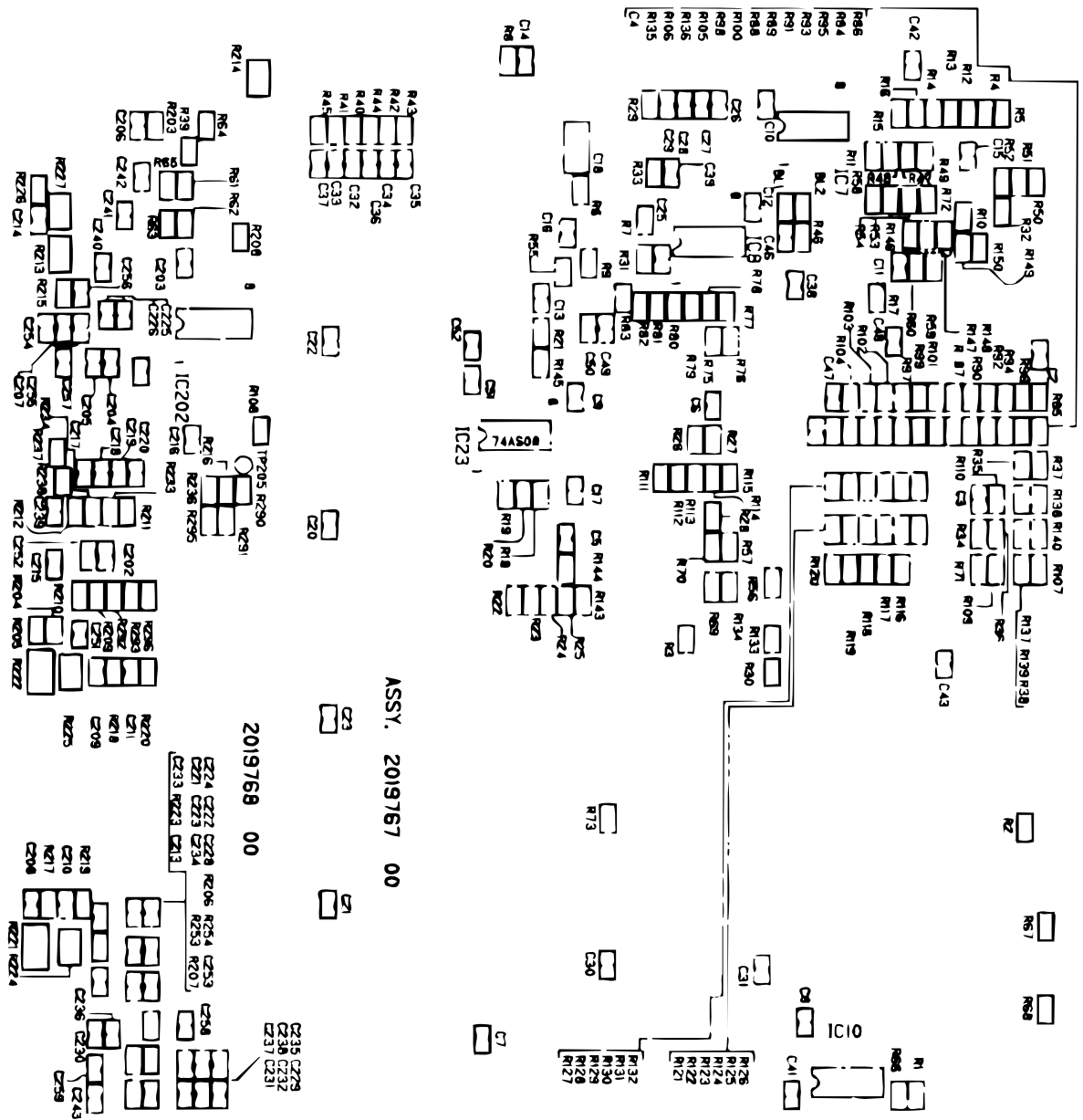

Figure A-8. C169 MAIN-B Component Layout (Rear)

EPSON OVERSEAS MARKETING LOCATIONS

EPSON AMERICA, INC

20770 Madrona Avenue,
P.O. Box 2842
Torrance, CA 90509-2842
Phone: (800) 922-8911
Fax: (310) 782-5220

EPSON DEUTCHLAND GmbH

Zülipicher Straße 6, 40549 Düsseldorf
Germany
Phone: 0211-56030
Fax: 0211-504-7787

EPSON UK LTD.

Campus 100, Maylands Avenue,
Hemel Hempstead, Herts,
HP2 7TJ, U.K.
Phone: 1442-61144
Fax: 1442-227227

EPSON FRANCE S.A.

68 bis, rue Marjolin 92300,
Levallois-Perret, France
Phone: 02-262331
Fax: 02-2440750

EPSON IBERICA

Avda. de Roma, 18-26
08290 Cerdanyola del Valles
Barcelona, Spain
Phone: 582.15.00
Fax: 582.15.55

EPSON ITALIA S.p.A.

V. le F. Ili Casiraghi, 427
20099 Sesto S. Giovanni MI, Italy
Phone: 02-262331
Fax: 02-2440750

EPSON AUSTRALIA PTY. LTD.

1/70 Gibbes Street,
Chatswood 2067 NSW, Australia
Phone: 02-415-9000
Fax: 02-417-0077

EPSON (SINGAPORE) PTE, LTD.

No. 1 Raffles Place #26-00
OUB Centre, Singapore 0104
Phone: 5330477
Fax: 5338119

EPSON HONG KONG LTD.

20/F, Harbour Centre,
25 Harbour Road, Wanchai,
Hong Kong
Phone: 585-4600
Fax: 827-4346

**EPSON TAIWAN TECHNOLOGY &
TRADING LTD.**

10F, No.287 Nonking E. Road, Sec . 3,
Taipei, Taiwan, R.O.C.
Phone: 2-717-7360
Fax: 2-712-9164

SEIKO**PRINTER**

80 Harashinden, Hirooka Shiojiri-shi,
Nagano-ken, 399-07, JAPAN
Phone: 0263-52-2552
Fax: 0263-54-4007
Telex: 3342-214 (SEPSON J)

As of October 1995

EPSON